

**EN29GL256****256 Megabit (32768K x 8-bit / 16384K x 16-bit) Flash Memory
Page mode Flash Memory, CMOS 3.0 Volt-only****FEATURES**

- Single power supply operation
 - Full voltage range: 2.7 to 3.6 volts read and write operations
- High performance
 - Access times as fast as 90 ns
- V_{IO} Input/Output 1.65 to 3.6 volts
 - All input levels (address, control, and DQ input levels) and outputs are determined by voltage on V_{IO} input. V_{IO} range is 1.65 to V_{CC}
- 8-word/16-byte page read buffer
- 32-word/64-byte write buffer reduces overall programming time for multiple-word updates
- Secured Silicon Sector region
 - 128-word/256-byte sector for permanent, secure identification through an 8-word/16-byte random Electronic Serial Number
 - Can be programmed and locked at the factory or by the customer
- Uniform 64Kword/128KByte Sector Architecture Two hundred fifty-six sectors
- Suspend and Resume commands for Program and Erase operations
- Write operation status bits indicate program and erase operation completion
- Support for CFI (Common Flash Interface)
- Persistent methods of Advanced Sector Protection
- WP#/ACC input
 - Accelerates programming time (when V_{HH} is applied) for greater throughput during system production
 - Protects first or last sector regardless of sector protection settings
- Hardware reset input (RESET#) resets device
- Ready/Busy# output (RY/BY#) detects program or erase cycle completion
- Minimum 100K program/erase endurance cycles.
- Package Options
 - 56-pin TSOP
 - 64-ball 11mm x 13mm BGA
- Industrial Temperature Range.

GENERAL DESCRIPTION

The EN29GL256 offers a fast page access time of 25 ns with a corresponding random access time as fast as 90 ns. It features a Write Buffer that allows a maximum of 32 words/64 bytes to be programmed in one operation, resulting in faster effective programming time than standard programming algorithms. This makes the device ideal for today's embedded applications that require higher density, better performance and lower power consumption.



CONNECTION DIAGRAMS

Figure 1. 56-pin Standard TSOP (Top View)

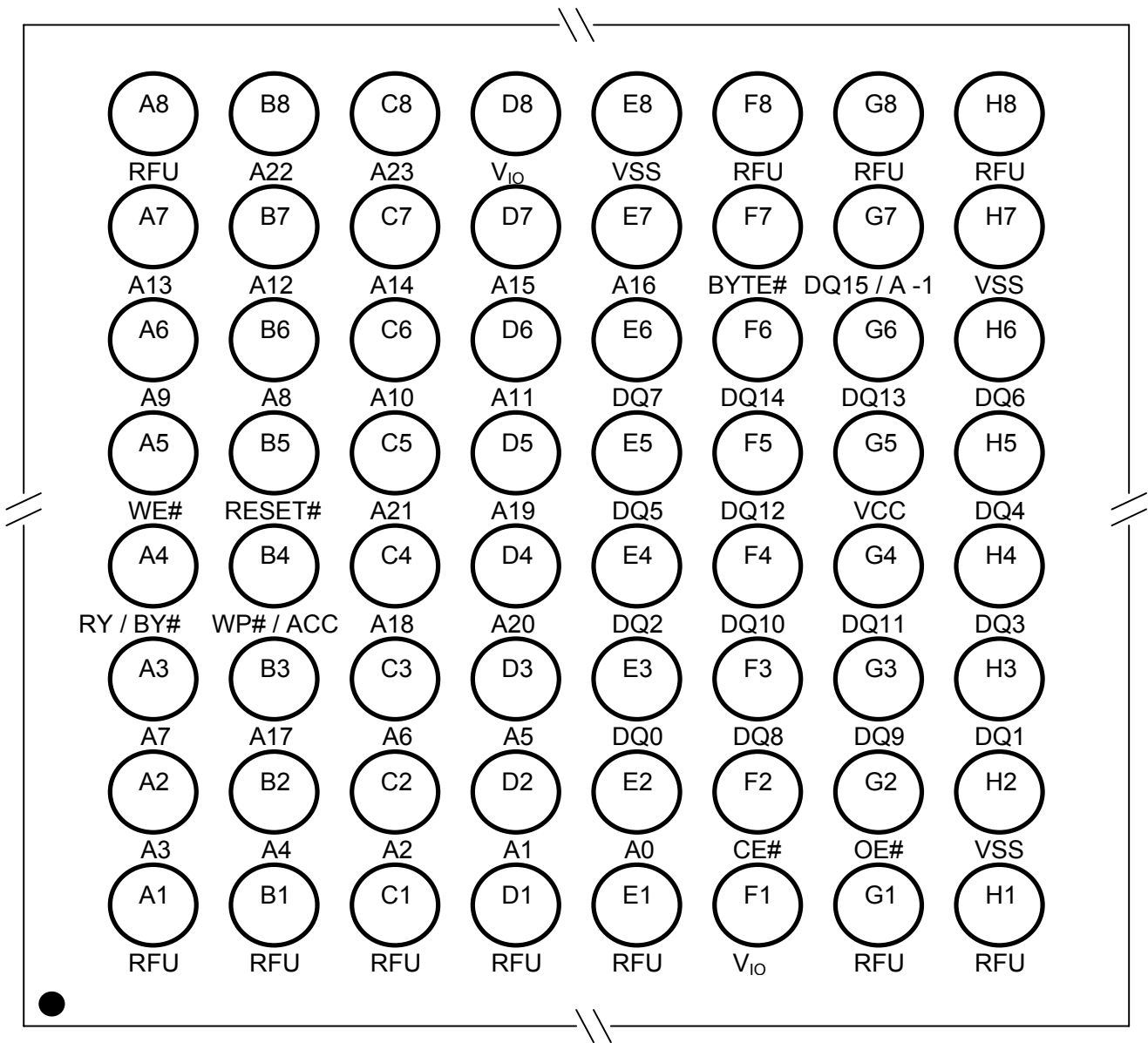

Note: RFU= Reserved for future use

Figure 2. 64-ball Ball Grid Array (Top View, Balls Facing Down)

Note: RFU= Reserved for future use

**TABLE 1. PIN DESCRIPTION**

Pin Name	Function
A23-A0	A23-A0
DQ0-DQ14	Data input/output.
DQ15 / A-1	DQ15 (data input/output, word mode), A-1 (LSB address input, byte mode)
CE#	Chip Enable
OE#	Output Enable
RESET#	Hardware Reset Pin
RY/BY#	Ready/Busy Output
WE#	Write Enable
Vcc	Supply Voltage (2.7-3.6V)
Vss	Ground
V _{IO}	V I/O Input.
BYTE#	Byte/Word mode selection
WP#/ACC	Write Protect / Acceleration Pin (WP# has an internal pull-up; when unconnected, WP# is at V _{IH} .)
RFU	Reserved for future use. Not Connected to anything

FIGURE 3. LOGIC DIAGRAM



Table 2. PRODUCT SELECTOR GUIDE

Product Number		EN29GL256
Speed Option	Full Voltage Range: $V_{CC}=2.7 - 3.6\text{ V}$ $V_{IO}=1.65 - 3.6\text{ V}$	-90
Max Access Time, ns (t_{acc})		90
Max Page Read Access, ns (t_{pacc})		25
Max CE# Access, ns (t_{ce})		90
Max OE# Access, ns (t_{oe})		35

BLOCK DIAGRAM

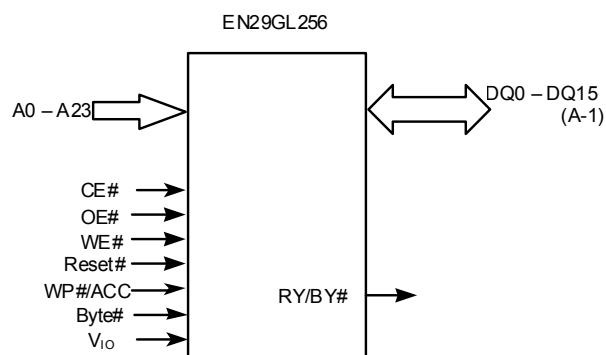
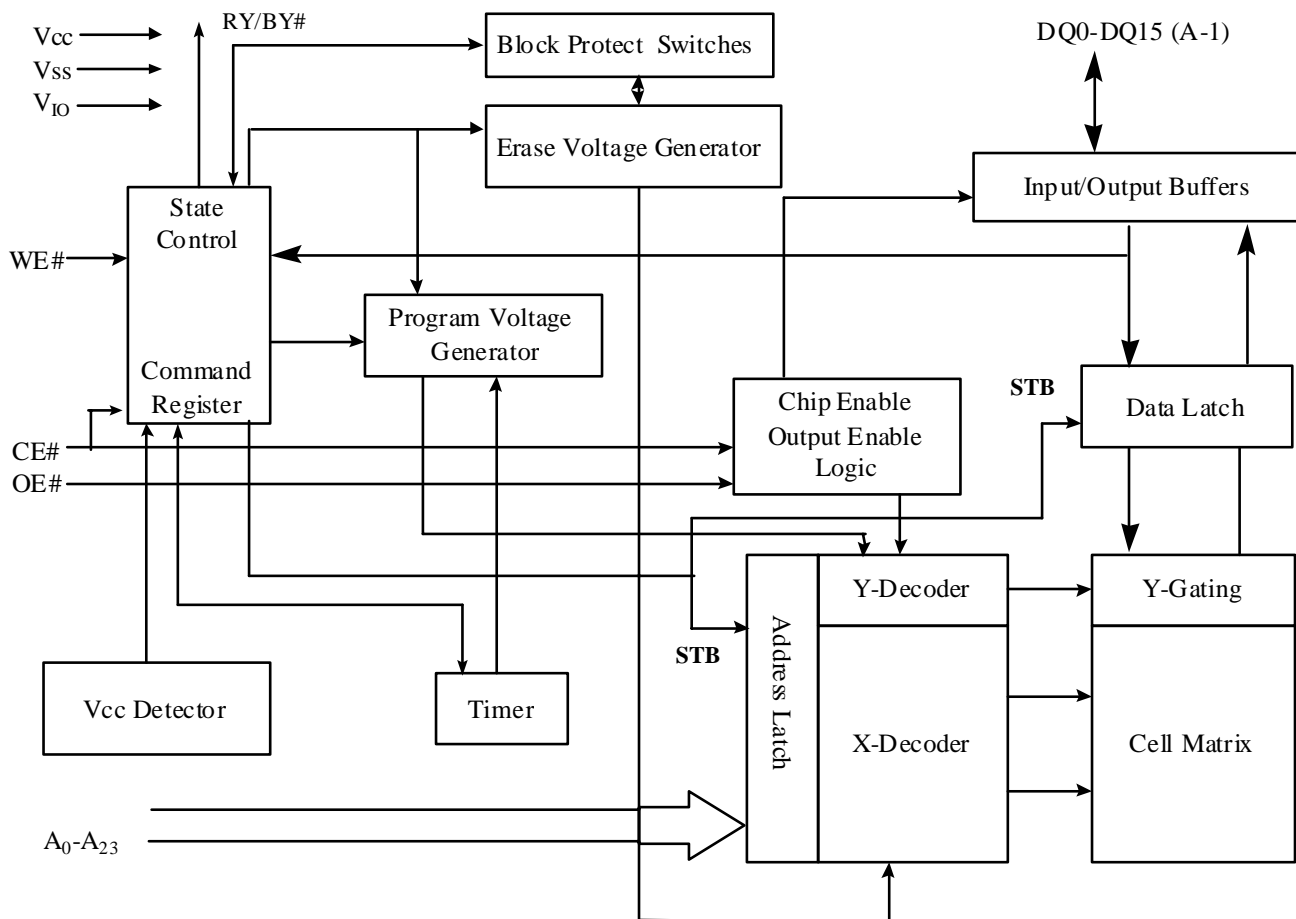



Product Overview

EN29GL256 is 256 Mb, 3.0-volt-only, page mode Flash devices optimized for today's embedded designs that demand a large storage array and rich functionality. This product offers uniform 64 Kword (128 KB) uniform sectors and feature V I/O control, allowing control and I/O signals to operate from 1.65 V to V_{CC} . Additional features include:

- Single word programming or a 32-word buffer for an increased programming speed
- Program Suspend/Resume and Erase Suspend/Resume
- Advanced Sector Protection methods for protecting sectors as required
- 128 words/256 bytes of Secured Silicon area for storing customer and factory secured information. The Secured Silicon Sector is One Time Programmable.



Table 3. Sector / Persistent Protection Sector Group Address Tables

PPB Group	A23-A18	Sector	Sector Size (Kbytes / Kwords)	Address Range (h) Word mode (x16)
PPB 0	000000	SA0	128/64	000000-00FFFF
PPB 1		SA1	128/64	010000-01FFFF
PPB 2		SA2	128/64	020000-02FFFF
PPB 3		SA3	128/64	030000-03FFFF
PPB 4	000001	SA4	128/64	040000-04FFFF
		SA5	128/64	050000-05FFFF
		SA6	128/64	060000-06FFFF
		SA7	128/64	070000-07FFFF
PPB 5	000010	SA8	128/64	080000-08FFFF
		SA9	128/64	090000-09FFFF
		SA10	128/64	0A0000-0AFFFF
		SA11	128/64	0B0000-0BFFFF
PPB 6	000011	SA12	128/64	0C0000-0CFFFF
		SA13	128/64	0D0000-0DFFFF
		SA14	128/64	0E0000-0EFFFF
		SA15	128/64	0F0000-0FFFFFFF
PPB 7	000100	SA16	128/64	100000-10FFFF
		SA17	128/64	110000-11FFFF
		SA18	128/64	120000-12FFFF
		SA19	128/64	130000-13FFFF
PPB 8	000101	SA20	128/64	140000-14FFFF
		SA21	128/64	150000-15FFFF
		SA22	128/64	160000-16FFFF
		SA23	128/64	170000-17FFFF
PPB 9	000110	SA24	128/64	180000-18FFFF
		SA25	128/64	190000-19FFFF
		SA26	128/64	1A0000-1AFFFF
		SA27	128/64	1B0000-1BFFFF
PPB 10	000111	SA28	128/64	1C0000-1CFFFF
		SA29	128/64	1D0000-1DFFFF
		SA30	128/64	1E0000-1EFFFF
		SA31	128/64	1F0000-1FFFFFFF
PPB 11	001000	SA32	128/64	200000-20FFFF
		SA33	128/64	210000-21FFFF
		SA34	128/64	220000-22FFFF
		SA35	128/64	230000-23FFFF
PPB 12	001001	SA36	128/64	240000-24FFFF
		SA37	128/64	250000-25FFFF
		SA38	128/64	260000-26FFFF
		SA39	128/64	270000-27FFFF
PPB 13	001010	SA40	128/64	280000-28FFFF



EN29GL256H/L

		SA41	128/64	290000-29FFFF
		SA42	128/64	2A0000-2AFFFF
		SA43	128/64	2B0000-2BFFFF
PPB 14	001011	SA44	128/64	2C0000-2CFFFF
		SA45	128/64	2D0000-2DFFFF
		SA46	128/64	2E0000-2EFFFF
		SA47	128/64	2F0000-2FFFFF
PPB 15	001100	SA48	128/64	300000-30FFFF
		SA49	128/64	310000-31FFFF
		SA50	128/64	320000-32FFFF
		SA51	128/64	330000-33FFFF
PPB 16	001101	SA52	128/64	340000-34FFFF
		SA53	128/64	350000-35FFFF
		SA54	128/64	360000-36FFFF
		SA55	128/64	370000-37FFFF
PPB 17	001110	SA56	128/64	380000-38FFFF
		SA57	128/64	390000-39FFFF
		SA58	128/64	3A0000-3AFFFF
		SA59	128/64	3B0000-3BFFFF
PPB 18	001111	SA60	128/64	3C0000-3CFFFF
		SA61	128/64	3D0000-3DFFFF
		SA62	128/64	3E0000-3EFFFF
		SA63	128/64	3F0000-3FFFFF
PPB 19	010000	SA64	128/64	400000-40FFFF
		SA65	128/64	410000-41FFFF
		SA66	128/64	420000-42FFFF
		SA67	128/64	430000-43FFFF
PPB 20	010001	SA68	128/64	440000-44FFFF
		SA69	128/64	450000-45FFFF
		SA70	128/64	460000-46FFFF
		SA71	128/64	470000-47FFFF
PPB 21	010010	SA72	128/64	480000-48FFFF
		SA73	128/64	490000-49FFFF
		SA74	128/64	4A0000-4AFFFF
		SA75	128/64	4B0000-4BFFFF
PPB 22	010011	SA76	128/64	4C0000-4CFFFF
		SA77	128/64	4D0000-4DFFFF
		SA78	128/64	4E0000-4EFFFF
		SA79	128/64	4F0000-4FFFFF
PPB 23	010100	SA80	128/64	500000-50FFFF
		SA81	128/64	510000-51FFFF
		SA82	128/64	520000-52FFFF
		SA83	128/64	530000-53FFFF

**EN29GL256H/L**

PPB 24	010101	SA84	128/64	540000-54FFFF
		SA85	128/64	550000-55FFFF
		SA86	128/64	560000-56FFFF
		SA87	128/64	570000-57FFFF
PPB 25	010110	SA88	128/64	580000-58FFFF
		SA89	128/64	590000-59FFFF
		SA90	128/64	5A0000-5AFFFF
		SA91	128/64	5B0000-5BFFFF
PPB 26	010111	SA92	128/64	5C0000-5CFFFF
		SA93	128/64	5D0000-5DFFFF
		SA94	128/64	5E0000-5EFFFF
		SA95	128/64	5F0000-5FFFFF
PPB 27	011000	SA96	128/64	600000-60FFFF
		SA97	128/64	610000-61FFFF
		SA98	128/64	620000-62FFFF
		SA99	128/64	630000-63FFFF
PPB 28	011001	SA100	128/64	640000-64FFFF
		SA101	128/64	650000-65FFFF
		SA102	128/64	660000-66FFFF
		SA103	128/64	670000-67FFFF
PPB 29	011010	SA104	128/64	680000-68FFFF
		SA105	128/64	690000-69FFFF
		SA106	128/64	6A0000-6AFFFF
		SA107	128/64	6B0000-6BFFFF
PPB 30	011011	SA108	128/64	6C0000-6CFFFF
		SA109	128/64	6D0000-6DFFFF
		SA110	128/64	6E0000-6EFFFF
		SA111	128/64	6F0000-6FFFFF
PPB 31	011100	SA112	128/64	700000-70FFFF
		SA113	128/64	710000-71FFFF
		SA114	128/64	720000-72FFFF
		SA115	128/64	730000-73FFFF
PPB 32	011101	SA116	128/64	740000-74FFFF
		SA117	128/64	750000-75FFFF
		SA118	128/64	760000-76FFFF
		SA119	128/64	770000-77FFFF
PPB 33	011110	SA120	128/64	780000-78FFFF
		SA121	128/64	790000-79FFFF
		SA122	128/64	7A0000-7AFFFF
		SA123	128/64	7B0000-7BFFFF
PPB 34	011111	SA124	128/64	7C0000-7CFFFF
		SA125	128/64	7D0000-7DFFFF
		SA126	128/64	7E0000-7EFFFF
		SA127	128/64	7F0000-7FFFFF

**EN29GL256H/L**

PPB 35	100000	SA128	128/64	800000–80FFFF
		SA129	128/64	810000–81FFFF
		SA130	128/64	820000–82FFFF
		SA131	128/64	830000–83FFFF
PPB 36	100001	SA132	128/64	840000–84FFFF
		SA133	128/64	850000–85FFFF
		SA134	128/64	860000–86FFFF
		SA135	128/64	870000–87FFFF
PPB 37	100010	SA136	128/64	880000–88FFFF
		SA137	128/64	890000–89FFFF
		SA138	128/64	8A0000–8AFFFF
		SA139	128/64	8B0000–8BFFFF
PPB 38	100011	SA140	128/64	8C0000–8CFFFF
		SA141	128/64	8D0000–8DFFFF
		SA142	128/64	8E0000–8EFFFF
		SA143	128/64	8F0000–8FFFFF
PPB 39	100100	SA144	128/64	900000–90FFFF
		SA145	128/64	910000–91FFFF
		SA146	128/64	920000–92FFFF
		SA147	128/64	930000–93FFFF
PPB 40	100101	SA148	128/64	940000–94FFFF
		SA149	128/64	950000–95FFFF
		SA150	128/64	960000–96FFFF
		SA151	128/64	970000–97FFFF
PPB 41	100110	SA152	128/64	980000–98FFFF
		SA153	128/64	990000–99FFFF
		SA154	128/64	9A0000–9AFFFF
		SA155	128/64	9B0000–9BFFFF
PPB 42	100111	SA156	128/64	9C0000–9CFFFF
		SA157	128/64	9D0000–9DFFFF
		SA158	128/64	9E0000–9EFFFF
		SA159	128/64	9F0000–9FFFFF
PPB 43	101000	SA160	128/64	A00000–A0FFFF
		SA161	128/64	A10000–A1FFFF
		SA162	128/64	A20000–A2FFFF
		SA163	128/64	A30000–A3FFFF
PPB 44	101001	SA164	128/64	A40000–A4FFFF
		SA165	128/64	A50000–A5FFFF
		SA166	128/64	A60000–A6FFFF
		SA167	128/64	A70000–A7FFFF
PPB 45	101010	SA168	128/64	A80000–A8FFFF
		SA169	128/64	A90000–A9FFFF
		SA170	128/64	AA0000–AAFFFF
		SA171	128/64	AB0000–ABFFFF



EN29GL256H/L

PPB 46	101011	SA172	128/64	AC0000-ACFFFF
		SA173	128/64	AD0000-ADFFFF
		SA174	128/64	AE0000-AEFFFF
		SA175	128/64	AF0000-AFFFFF
PPB 47	101100	SA176	128/64	B00000-B0FFFF
		SA177	128/64	B10000-B1FFFF
		SA178	128/64	B20000-B2FFFF
		SA179	128/64	B30000-B3FFFF
PPB 48	101101	SA180	128/64	B40000-B4FFFF
		SA181	128/64	B50000-B5FFFF
		SA182	128/64	B60000-B6FFFF
		SA183	128/64	B70000-B7FFFF
PPB 49	101110	SA184	128/64	B80000-B8FFFF
		SA185	128/64	B90000-B9FFFF
		SA186	128/64	BA0000-BAFFFF
		SA187	128/64	BB0000-BBFFFF
PPB 50	101111	SA188	128/64	BC0000-BCFFFF
		SA189	128/64	BD0000-BDFFFF
		SA190	128/64	BE0000-BEFFFF
		SA191	128/64	BF0000-BFXXXX
PPB 51	110000	SA192	128/64	C00000-C0FFFF
		SA193	128/64	C10000-C1FFFF
		SA194	128/64	C20000-C2FFFF
		SA195	128/64	C30000-C3FFFF
PPB 52	110001	SA196	128/64	C40000-C4FFFF
		SA197	128/64	C50000-C5FFFF
		SA198	128/64	C60000-C6FFFF
		SA199	128/64	C70000-C7FFFF
PPB 53	110010	SA200	128/64	C80000-C8FFFF
		SA201	128/64	C90000-C9FFFF
		SA202	128/64	CA0000-CAFFFF
		SA203	128/64	CB0000-CBFFFF
PPB 54	110011	SA204	128/64	CC0000-CCFFFF
		SA205	128/64	CD0000-CDFFFF
		SA206	128/64	CE0000-CEFFFF
		SA207	128/64	CF0000-CFXXXX
PPB 55	110100	SA208	128/64	D00000-D0FFFF
		SA209	128/64	D10000-D1FFFF
		SA210	128/64	D20000-D2FFFF
		SA211	128/64	D30000-D3FFFF
PPB 56	110101	SA212	128/64	D40000-D4FFFF
		SA213	128/64	D50000-D5FFFF
		SA214	128/64	D60000-D6FFFF



EN29GL256H/L

		SA215	128/64	D70000-D7FFFF
PPB 57	110110	SA216	128/64	D80000-D8FFFF
		SA217	128/64	D90000-D9FFFF
		SA218	128/64	DA0000-DAFFFF
		SA219	128/64	DB0000-DBFFFF
		SA9220	128/64	DC0000-DCFFFF
PPB 58	110111	SA221	128/64	DD0000-DDFFFF
		SA222	128/64	DE0000-DEFFFF
		SA223	128/64	DF0000-DFFFFF
		SA224	128/64	E00000-E0FFFF
PPB 59	111000	SA225	128/64	E10000-E1FFFF
		SA226	128/64	E20000-E2FFFF
		SA227	128/64	E30000-E3FFFF
		SA228	128/64	E40000-E4FFFF
PPB 60	111001	SA229	128/64	E50000-E5FFFF
		SA230	128/64	E60000-E6FFFF
		SA231	128/64	E70000-E7FFFF
		SA232	128/64	E80000-E8FFFF
PPB 61	111010	SA233	128/64	E90000-E9FFFF
		SA234	128/64	EA0000-EAFFFF
		SA235	128/64	EB0000-EBFFFF
		SA236	128/64	EC0000-ECFFFF
PPB 62	111011	SA237	128/64	ED0000-EDFFFF
		SA238	128/64	EE0000-EEFFFF
		SA239	128/64	EF0000-EFFFFF
		SA240	128/64	F00000-F0FFFF
PPB 63	111100	SA241	128/64	F10000-F1FFFF
		SA242	128/64	F20000-F2FFFF
		SA243	128/64	F30000-F3FFFF
		SA244	128/64	F40000-F4FFFF
PPB 64	111101	SA245	128/64	F50000-F5FFFF
		SA246	128/64	F60000-F6FFFF
		SA247	128/64	F70000-F7FFFF
		SA248	128/64	F80000-F8FFFF
PPB 65	111110	SA249	128/64	F90000-F9FFFF
		SA250	128/64	FA0000-FAFFFF
		SA251	128/64	FB0000-FBFFFF
		SA252	128/64	FC0000-FCFFFF
PPB 66	111111	SA253	128/64	FD0000-FDFFFF
PPB 67		SA254	128/64	FE0000-FEFFFF
PPB 68		SA255	128/64	FF0000-FFFFFF
PPB 69				



Table 4. Device OPERATING MODES

256M FLASH USER MODE TABLE

Operation	CE#	OE#	WE#	RESET#	WP#/ACC	A0-A23	DQ0-DQ7	DQ8-DQ15	
								BYTE# = V _{IH}	BYTE# = V _{IL}
Read	L	L	H	H	L/H	A _{IN}	D _{OUT}	D _{OUT}	DQ8-DQ14 = High-Z, DQ15 = A-1
Write	L	H	L	H	(Note 1)	A _{IN}	D _{IN}	D _{IN}	
Accelerated Program	L	H	L	H	V _{HH}	A _{IN}	D _{IN}	D _{IN}	
CMOS Standby	V _{CC} ±0.3V	X	X	V _{CC} ±0.3V	H	X	High-Z	High-Z	High-Z
Output Disable	L	H	H	H	L/H	X	High-Z	High-Z	High-Z
Hardware Reset	X	X	X	L	L/H	X	High-Z	High-Z	High-Z

Notes:

- Addresses are A23:A0 in word mode; A23:A-1 in byte mode.
- If WP# = VIL, on the outermost sector remains protected. If WP# = VIH, the outermost sector is unprotected. WP# has an internal pull-up; when unconnected, WP# is at VIH. All sectors are unprotected when shipped from the factory (The Secured Silicon Sector can be factory protected depending on version ordered.)
- DIN or DOUT as required by command sequence, data polling, or sector protect algorithm.

Legend

L = Logic Low = VIL, H = Logic High = VIH, VHH = 8.5–9.5V, X = Don't Care, AIN = Address In, DIN = Data In, DOUT = Data Out



USER MODE DEFINITIONS

Word / Byte Configuration

The BYTE# pin controls whether the device data I/O pins operate in the byte or word configuration. If the BYTE# pin is set at logic '1', the device is in word configuration, DQ0-DQ15 are active and controlled by CE# and OE#.

If the BYTE# pin is set at logic '0', the device is in byte configuration, and only data I/O pins DQ0-DQ7 are active and controlled by CE# and OE#. The data I/O pins DQ8-DQ14 are tri-stated, and the DQ15 pin is used as an input for the LSB (A-1) address function.

V_{IO} Control

The V_{IO} allows the host system to set the voltage levels that the device generates and tolerates on all inputs and outputs (address, control, and DQ signals). V_{IO} range is 1.65 to V_{CC}. For example, a V_{IO} of 1.65-3.6 volts allows for I/O at the 1.65 or 3.6 volt levels, driving and receiving signals to and from other 1.65 or 3.6 V devices on the same data bus.

Read

All memories require access time to output array data. In a read operation, data is read from one memory location at a time. Addresses are presented to the device in random order, and the propagation delay through the device causes the data on its outputs to arrive with the address on its inputs.

The device defaults to reading array data after device power-up or hardware reset. To read data from the memory array, the system must first assert a valid address on A23-A0, while driving OE# and CE# to VIL. WE# must remain at VIH. All addresses are latched on the falling edge of CE#. Data will appear on DQ15-DQ0 after address access time (t_{ACC}), which is equal to the delay from stable addresses to valid output data. The OE# signal must be driven to VIL. Data is output on DQ15-DQ0 pins after the access time (t_{OE}) has elapsed from the falling edge of OE#, assuming the t_{ACC} access time has been met.

Page Read Mode

The device is capable of fast page mode read and is compatible with the page mode Mask ROM read operation. This mode provides faster read access speed for random locations within a page. The page size of the device is 8 words/16 bytes. The appropriate page is selected by the higher address bits A23-A3. Address bits A2-A0 in word mode (A2 to A-1 in byte mode) determine the specific word within a page. The microprocessor supplies the specific word location.

The random or initial page access is equal to t_{ACC} or t_{CE} and subsequent page read accesses (as long as the locations specified by the microprocessor falls within that page) is equivalent to t_{PACC}. When CE# is deasserted and reasserted for a subsequent access, the access time is t_{ACC} or t_{CE}. Fast page mode accesses are obtained by keeping the "read-page addresses" constant and changing the "intra-read page" addresses.

Autoselect

The Autoselect mode provides manufacturer ID, Device identification, and sector protection information, through identifier codes output from the internal register (separate from the memory array) on DQ7-DQ0.

The device only support to use autoselect command to access autoselect codes. It does not support to apply VID on address pin A9.



- The Autoselect command sequence may be written to an address within a sector that is either in the read or **erase-suspend-read mode**.
- The Autoselect command may not be written while the device is actively programming or erasing.
- The system must write the reset command to return to the read mode (or erase-suspend-read mode if the sector was previously in Erase Suspend).
- When verifying sector protection, the sector address must appear on the appropriate highest order address bits. The remaining address bits are don't care and then read the corresponding identifier code on DQ15-DQ0.

Program/Erase Operations

These devices are capable of several modes of programming and or erase operations which are described in detail in the following sections.

During a write operation, the system must drive CE# and WE# to VIL and OE# to VIH when providing address, command, and data. Addresses are latched on the last falling edge of WE# or CE#, while data is latched on the 1st rising edge of WE# or CE#.

Note the following:

- When the Embedded Program algorithm is complete, the device returns to the read mode.
- The system can determine the status of the program operation by reading the DQ status bits. Refer to the Write Operation Status on page 25 for information on these status bits.
- An "0" cannot be programmed back to a "1." A succeeding read shows that the data is still "0."
- Only erase operations can convert a "0" to a "1."
- Any commands written to the device during the Embedded Program/Erase are ignored except the Suspend commands.
- Secured Silicon Sector, Autoselect, and CFI functions are unavailable when a program operation is in progress.
- A hardware reset and/or power removal immediately terminates the Program/Erase operation and the Program/Erase command sequence should be reinitiated once the device has returned to the read mode to ensure data integrity.
- Programming is allowed in any sequence and across sector boundaries for single word programming operation.
- Programming to the same word address multiple times without intervening erases is permitted.

Single Word Programming

Single word programming mode is one method of programming the Flash. In this mode, four Flash command write cycles are used to program an individual Flash address. The data for this programming operation could be 8 or 16-bits wide.

While the single word programming method is supported by most devices, in general Single Word Programming is not recommended for devices that support Write Buffer Programming.

When the Embedded Program algorithm is complete, the device then returns to the read mode and addresses are no longer latched. The system can determine the status of the program operation by reading the DQ status bits.

- During programming, any command (except the Suspend Program command) is ignored.
- The Secured Silicon Sector, Autoselect, and CFI functions are unavailable when a program operation is in progress.
- A hardware reset immediately terminates the program operation. The program command sequence should be reinitiated once the device has returned to the read mode, to ensure data integrity.
- Programming to the same address multiple times continuously (for example, "walking" a bit within a word) is permitted.

Figure 4. Single Word Program

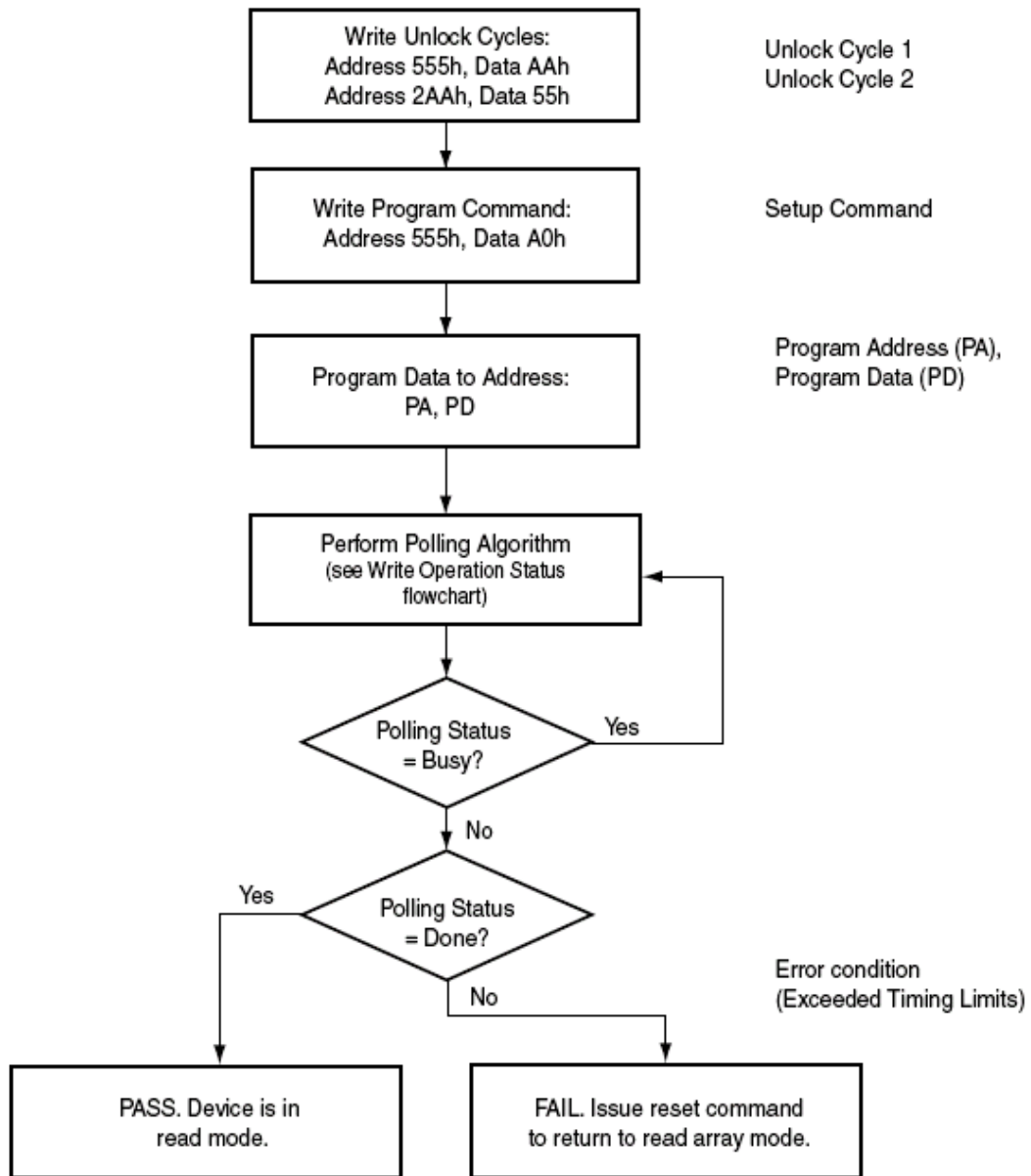



Write Buffer Programming

Write Buffer Programming allows the system to write a maximum of 32 words in one programming operation. This results in a faster effective word programming time than the standard “word” programming algorithms. The Write Buffer Programming command sequence is initiated by first writing two unlock cycles. This is followed by a third write cycle containing the Write Buffer Load command written at the Sector Address in which programming occurs. At this point, the system writes the number of “word locations minus 1” that are loaded into the page buffer at the Sector Address in which programming occurs. This tells the device how many write buffer addresses are loaded with data and therefore when to expect the “Program Buffer to Flash” confirm command. The number of locations to program cannot exceed the size of the write buffer or the operation aborts. (Number loaded = the number of locations to program minus 1. For example, if the system programs 6 address locations, then 05h should be written to the device.)

The system then writes the starting address/data combination. This starting address is the first address/data pair to be programmed, and selects the “write-buffer-page” address. All subsequent address/data pairs must fall within the elected-write-buffer-page.

The “write-buffer-page” is selected by using the addresses A23–A5.

The “write-buffer-page” addresses must be the same for all address/data pairs loaded into the write buffer. (This means Write Buffer Programming cannot be performed across multiple “write-buffer-pages.” This also means that Write Buffer Programming cannot be performed across multiple sectors. If the system attempts to load programming data outside of the selected “write-buffer-page”, the operation ABORTs.)

After writing the Starting Address/Data pair, the system then writes the remaining address/data pairs into the write buffer.

Note that if a Write Buffer address location is loaded multiple times, the “address/data pair” counter is decremented for every data load operation. Also, the last data loaded at a location before the “Program Buffer to Flash” confirm command is the data programmed into the device. It is the software's responsibility to comprehend ramifications of loading a write-buffer location more than once. The counter decrements for each data load operation, NOT for each unique write-buffer-address location. Once the specified number of write buffer locations have been loaded, the system must then write the “Program Buffer to Flash” command at the Sector Address. Any other address/data write combinations abort the Write Buffer Programming operation. The Write Operation Status bits should be used while monitoring the last address location loaded into the write buffer. This eliminates the need to store an address in memory because the system can load the last address location, issue the program confirm command at the last loaded address location, and then check the write operation status at that same address. DQ7, DQ6, DQ5, DQ2, and DQ1 should be monitored to determine the device status during Write Buffer Programming.

The write-buffer “embedded” programming operation can be suspended using the standard suspend/resume commands. Upon successful completion of the Write Buffer Programming operation, the device returns to READ mode.

The Write Buffer Programming Sequence is ABORTED under any of the following conditions:

- Load a value that is greater than the page buffer size during the “Number of Locations to Program” step.
- Write to an address in a sector different than the one specified during the Write-Buffer-Load command.
- Write an Address/Data pair to a different write-buffer-page than the one selected by the “Starting Address” during the “write buffer data loading” stage of the operation.
- Writing anything other than the Program to Buffer Flash Command after the specified number of “data load” cycles.

The ABORT condition is indicated by DQ1 = 1, DQ7 = DATA# (for the “last address location loaded”), DQ6 = TOGGLE, DQ5 = 0. This indicates that the Write Buffer Programming Operation was ABORTED. Note that the Secured Silicon sector, autoselect, and CFI functions are unavailable when a program

operation is in progress.

Write buffer programming is allowed in any sequence of memory (or address) locations. These flash devices are capable of handling multiple write buffer programming operations on the same write buffer address range without intervening erases.

Use of the write buffer is strongly recommended for programming when multiple words are to be programmed.

Figure 5. Write Buffer Programming Operation

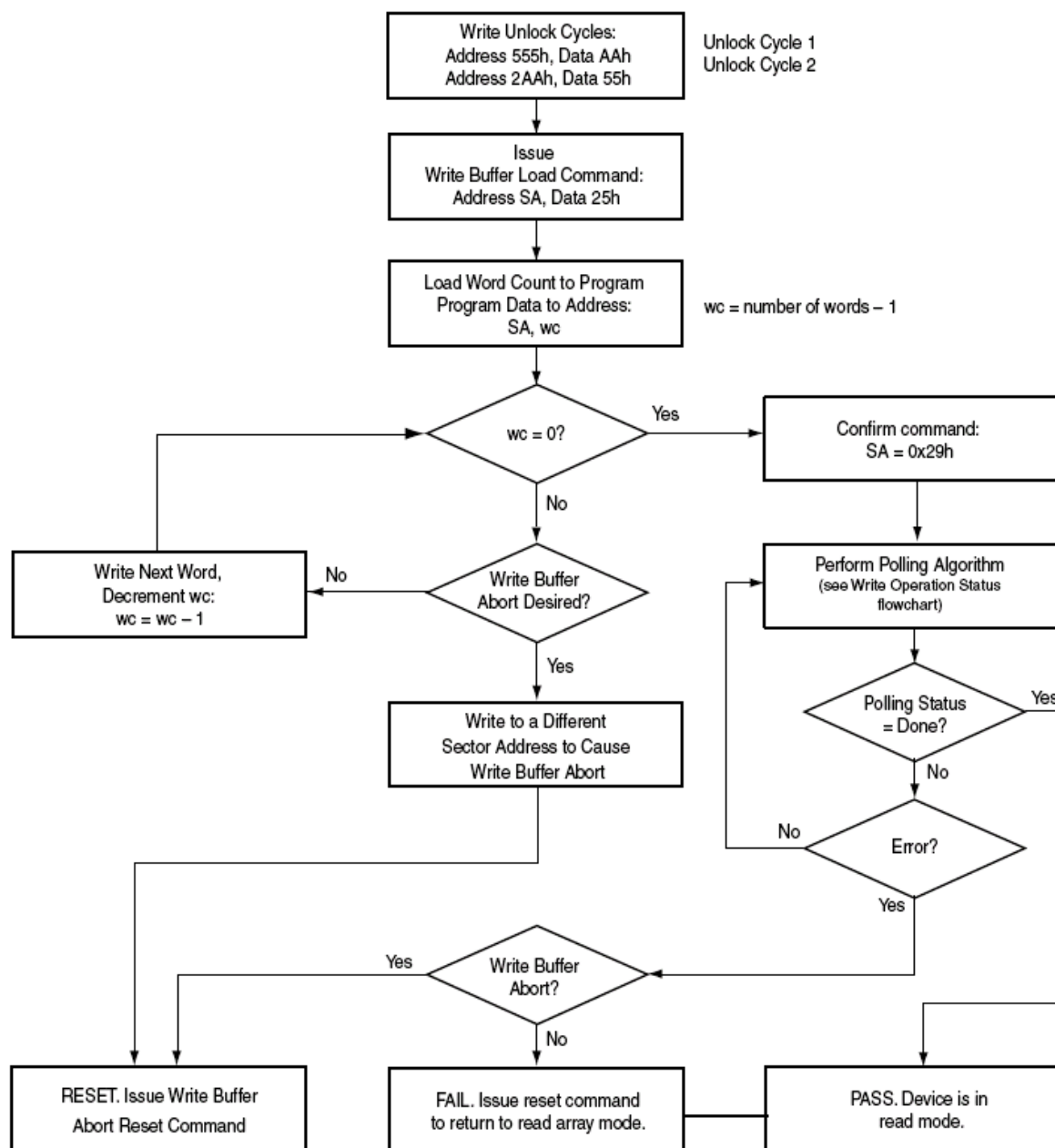

Sector Erase

Sector erase is a six bus cycle operation. The sector erase command sequence is initiated by writing two un-lock cycles, followed by a set-up command. Two additional unlock write cycles are then followed by the address of the sector to be erased, and the sector erase command. The Command Definitions table shows the address and data requirements for the sector erase command sequence.

Once the sector erase operation has begun, only the Sector Erase Suspend command is valid. All other commands are ignored. If there are several sectors to be erased, Sector Erase Command sequences must be issued for each sector. That is, only **a sector address can be specified for each Sector Erase command**. Users must issue another Sector Erase command for the next sector to be erased after the previous one is completed.

When the Embedded Erase algorithm is completed, the device returns to reading array data and addresses are no longer latched. The system can determine the status of the erase operation by using DQ7, DQ6, or DQ2. Refer to "Write Operation Status" for information on these status bits. Flowchart 4 illustrates the algorithm for the erase operation. Refer to the Erase/Program Operations tables in the "AC Characteristics" section for parameters, and to the Sector Erase Operations Timing diagram for timing waveforms.

Figure 6. Sector Erase Operation

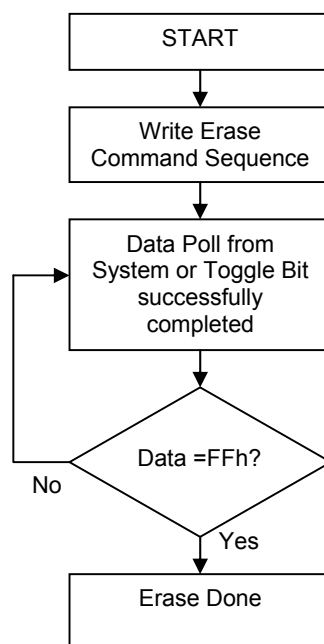



Chip Erase Command Sequence

Chip erase is a six-bus cycle operation as indicated by Table 13. These commands invoke the Embedded Erase algorithm, which does not require the system to preprogram prior to erase. The Embedded Erase algorithm automatically preprograms and verifies the entire memory to an all zero data pattern prior to electrical erase. After a successful chip erase, all locations of the chip contain FFFFh. The system is not required to provide any controls or timings during these operations.

When the Embedded Erase algorithm is complete, that sector returns to the read mode and addresses are no longer latched. The system can determine the status of the erase operation by using DQ7 or DQ6/DQ2. Refer to "Write Operation Status" for information on these status bits.

Any commands written during the chip erase operation are ignored. However, note that a hardware reset immediately terminates the erase operation. If that occurs, the chip erase command sequence should be reinitiated once that sector has returned to reading array data, to ensure the entire array is properly erased.

Erase Suspend/Erase Resume Commands

The Erase Suspend command allows the system to interrupt a sector erase operation and then read data from, or program data to, any sector not selected for erasure. The sector address is required when writing this command. This command is valid only during the sector erase operation. The Sector Erase Suspend command is ignored if written during the chip erase operation or Embedded Program algorithm. Addresses are don't-cares when writing the Sector Erase Suspend command.

When the Erase Suspend command is written during the sector erase operation, the device requires a maximum of 20 μ s to suspend the erase operation.

After the erase operation has been suspended, the device enters the erase-suspend-read mode. The system can read data from or program data to any sector not selected for erasure. (The device "erase suspends" all sectors selected for erasure.) Reading at any address within erase-suspended sectors produces status information on DQ7-DQ0. The system can use DQ7, or DQ6, and DQ2 together, to determine if a sector is actively erasing or is erase-suspended.

After an erase-suspended program operation is complete, the device returns to the erase-suspend-read mode. The system can determine the status of the program operation using write operation status bits, just as in the standard program operation.

In the erase-suspend-read mode, the system can also issue the Autoselect command sequence. Refer to Write Buffer Programming and the Autoselect for details.

To resume the sector erase operation, the system must write the Erase Resume command. The address of the erase-suspended sector is required when writing this command. Further writes of the Resume command are ignored. Another Erase Suspend command can be written after the chip has resumed erasing.

Program Suspend/Program Resume Commands

The Program Suspend command allows the system to interrupt an embedded programming operation or a "Write to Buffer" programming operation so that data can read from any non-suspended sector. When the Program Suspend command is written during a programming process, the device halts the programming operation within 15 μ s maximum (5 μ s typical) and updates the status bits. Addresses are "don't-cares" when writing the Program Suspend command.

After the programming operation has been suspended, the system can read array data from any nonsuspended sector. The Program Suspend command may also be issued during a programming operation while an erase is suspended. In this case, data may be read from any addresses not within a sector in Erase Suspend or Program Suspend. If a read is needed from the Secured Silicon Sector area, then user must use the proper command sequences to enter and exit this region.



The system may also write the Autoselect Command Sequence when the device is in Program Suspend mode. The device allows reading Autoselect codes in the suspended sectors, since the codes are not stored in the memory array. When the device exits the Autoselect mode, the device reverts to Program Suspend mode, and is ready for another valid operation.

After the Program Resume command is written, the device reverts to programming. The system can determine the status of the program operation using the write operation status bits, just as in the standard program operation.

The system must write the Program Resume command (address bits are “don't care”) to exit the Program Suspend mode and continue the programming operation. Further writes of the Program Resume command are ignored. Another Program Suspend command can be written after the device has resumed programming.

Accelerated Program

Accelerated single word programming and write buffer programming operations are enabled through the WP#/ACC pin. This method is faster than the standard program command sequences.

If the system asserts V_{HH} on this input, the device automatically enters the Accelerated Program mode and uses the higher voltage on the input to reduce the time required for program operations. The system can then use the Write Buffer Load command sequence provided by the Accelerated Program mode. Note that if a “Write-to-Buffer-Abort Reset” is required while in Accelerated Program mode, the full 3-cycle RESET command sequence must be used to reset the device. Removing V_{HH} from the ACC input, upon completion of the embedded program operation, returns the device to normal operation.

- Sectors must be unlocked prior to raising WP#/ACC to V_{HH} .
- The WP#/ACC pin must not be at V_{HH} for operations other than accelerated programming, or device damage may result.
- It is recommended that WP#/ACC apply V_{HH} after power-up sequence is completed. In addition, it is recommended that WP#/ACC apply from V_{HH} to V_{IH}/V_{IL} before powering down V_{CC}/V_{IO} .

Write Operation Status

The device provides several bits to determine the status of a program or erase operation. The following subsections describe the function of DQ1, DQ2, DQ3, DQ5, DQ6, and DQ7.

DQ7: Data# Polling

The Data# Polling bit, DQ7, indicates to the host system whether an Embedded Program or Erase algorithm is in progress or completed, or whether the device is in Erase Suspend. Data# Polling is valid after the rising edge of the final WE# pulse in the command sequence. Note that the Data# Polling is valid only for the last word being programmed in the write-buffer-page during Write Buffer Programming. Reading Data# Polling status on any word other than the last word to be programmed in the write-buffer-page returns false status information.

During the Embedded Program algorithm, the device outputs on DQ7 the complement of the datum programmed to DQ7. This DQ7 status also applies to programming during Erase Suspend. When the Embedded Program algorithm is complete, the device outputs the datum programmed to DQ7. The system must provide the program address to read valid status information on DQ7. If a program address falls within a protected sector, Data# polling on DQ7 is active, then that sector returns to the read mode.

During the Embedded Erase Algorithm, Data# polling produces a “0” on DQ7. When the Embedded Erase algorithm is complete, or if the device enters the Erase Suspend mode, Data# Polling produces a “1” on DQ7. The system must provide an address within any of the sectors selected for erasure to read valid status information on DQ7.

After an erase command sequence is written, if all sectors selected for erasing are protected, Data# Polling on DQ7 is active for approximately 100 μ s, then the device returns to the read mode. If not all selected sectors are protected, the Embedded Erase algorithm erases the unprotected sectors, and ignores the selected sectors that are protected. However, if the system reads DQ7 at an address within a protected sector, the status may not be valid.

Just prior to the completion of an Embedded Program or Erase operation, DQ7 may change asynchronously with DQ6-DQ0 while Output Enable (OE#) is asserted low. That is, the device may change from providing status information to valid data on DQ7. Depending on when the system samples the DQ7 output, it may read the status or valid data. Even if the device has completed the program or erase operation and DQ7 has valid data, the data outputs on DQ6-DQ0 may be still invalid. Valid data on DQ7-DQ0 appears on successive read cycles.

Figure 7. Write Operation Status Flowchart

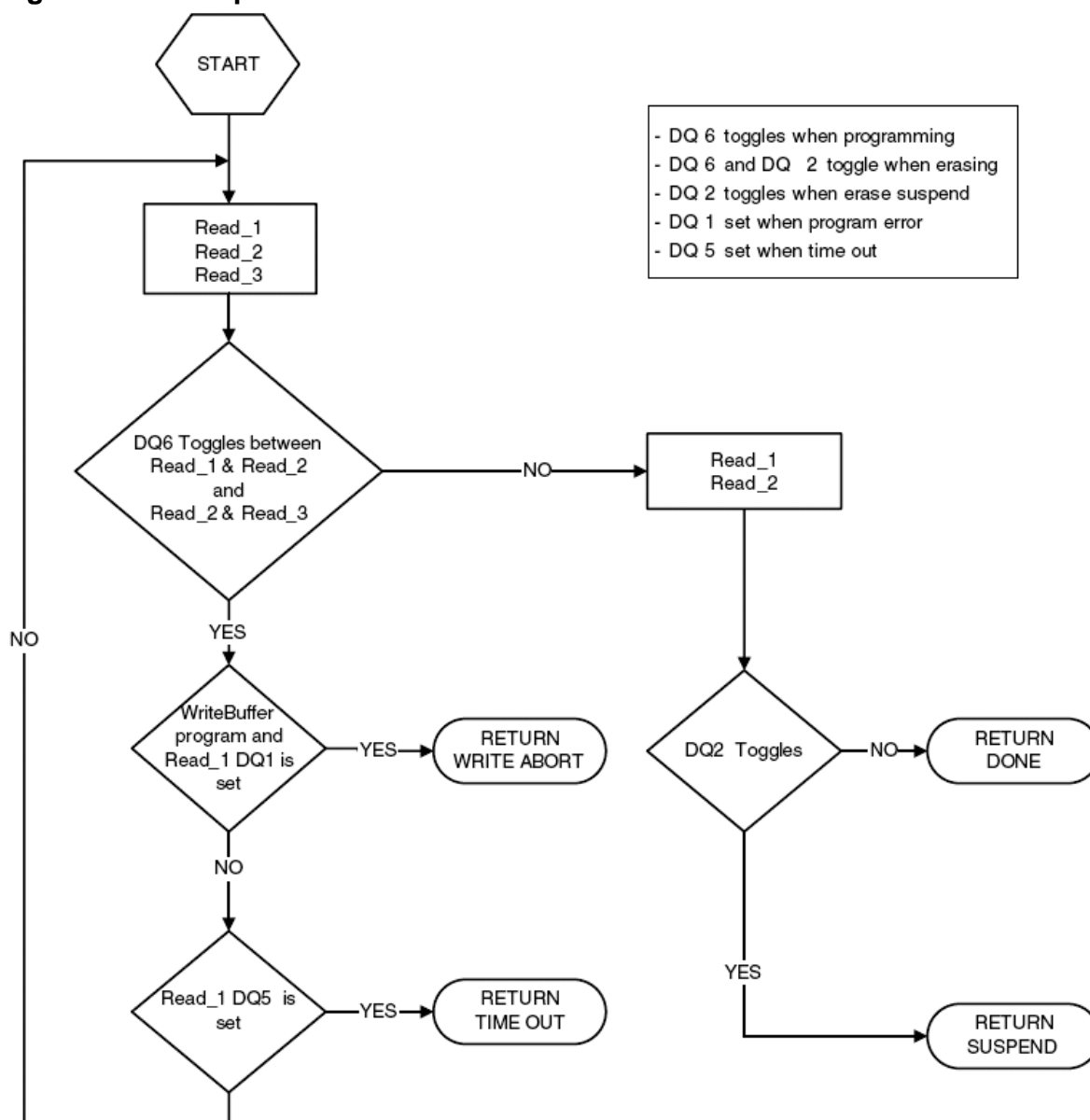

DQ6: Toggle Bit I

Toggle Bit I on DQ6 indicates whether an Embedded Program or Erase algorithm is in progress or complete, or whether the device has entered the Erase Suspend mode. Toggle Bit I may be read at any



address, and is valid after the rising edge of the final WE# pulse in the command sequence (prior to the program or erase operation), and during the sector erase time-out.

During an Embedded Program or Erase algorithm operation, successive read cycles to any address that is being programmed or erased causes DQ6 to toggle. When the operation is complete, DQ6 stops toggling.

After an erase command sequence is written, if all sectors selected for erasing are protected, DQ6 toggles for approximately 100 μ s, then returns to reading array data. If not all selected sectors are protected, the Embedded Erase algorithm erases the unprotected sectors, and ignores the selected sectors that are protected.

The system can use DQ6 and DQ2 together to determine whether a sector is actively erasing or is erase 2suspended. When the device is actively erasing (that is, the Embedded Erase algorithm is in progress), DQ6 toggles. When the device enters the Erase Suspend mode, DQ6 stops toggling. However, the system must also use DQ2 to determine which sectors are erasing or erase-suspended. Alternatively, the system can use DQ7.

If a program address falls within a protected sector, DQ6 toggles for approximately 1 μ s after the program command sequence is written, then returns to reading array data. DQ6 also toggles during the erase-suspend-program mode, and stops toggling once the Embedded Program Algorithm is complete. Toggle Bit I on DQ6 requires either OE# or CE# to be de-asserted and reasserted to show the change in state.

DQ2: Toggle Bit II

The “Toggle Bit II” on DQ2, when used with DQ6, indicates whether a particular sector is actively erasing (that is, the Embedded Erase algorithm is in progress), or whether that sector is erase-suspended. Toggle Bit II is valid after the rising edge of the final WE# pulse in the command sequence. DQ2 toggles when the system reads at addresses within those sectors that have been selected for erasure. But DQ2 cannot distinguish whether the sector is actively erasing or is erase-suspended. DQ6, by comparison, indicates whether the device is actively erasing, or is in Erase Suspend, but cannot distinguish which sectors are selected for erasure. Thus, both status bits are required for sector and mode information.

Reading Toggle Bits DQ6/DQ2

Whenever the system initially begins reading toggle bit status, it must read DQ7–DQ0 at least twice in a row to determine whether a toggle bit is toggling. Typically, the system would note and store the value of the toggle bit after the first read. After the second read, the system would compare the new value of the toggle bit with the first. If the toggle bit is not toggling, the device has completed the program or erases operation. The system can read array data on DQ7–DQ0 on the following read cycle. However, if after the initial two read cycles, the system determines that the toggle bit is still toggling, the system also should note whether the value of DQ5 is high. If it is, the system should then determine again whether the toggle bit is toggling, since the toggle bit may have stopped toggling just as DQ5 went high. If the toggle bit is no longer toggling, the device has successfully completed the program or erases operation. If it is still toggling, the device did not complete the operation successfully, and the system must write the reset command to return to reading array data. The remaining scenario is that the system initially determines that the toggle bit is toggling and DQ5 has not gone high. The system may continue to monitor the toggle bit and DQ5 through successive read cycles, determining the status as described in the previous paragraph. Alternatively, it may choose to perform other system tasks. In this case, the system must start at the beginning of the algorithm when it returns to determine the status of the operation.

Note

When verifying the status of a write operation (embedded program/erase) of a memory sector, DQ6 and DQ2 toggle between high and low states in a series of consecutive and contiguous status read cycles. In order for this toggling behavior to be properly observed, the consecutive status bit reads must not be interleaved with read accesses to other memory sectors. If it is not possible to temporarily prevent reads to other memory sectors, then it is recommended to use the DQ7 status bit as the alternative method of determining the active or inactive status of the write operation.



DQ5: Exceeded Timing Limits

DQ5 indicates whether the program or erase time has exceeded a specified internal pulse count limit. Under these conditions DQ5 produces a “1,” indicating that the program or erase cycle was not successfully completed. The device does not output a 1 on DQ5 if the system tries to program a 1 to a location that was previously programmed to 0. Only an erase operation can change a 0 back to a 1. Under this condition, the device ignores the bit that was incorrectly instructed to be programmed from a 0 to a 1, while any other bits that were correctly requested to be changed from 1 to 0 are programmed. Attempting to program a 0 to a 1 is masked during the programming operation. Under valid DQ5 conditions, the system must write the reset command to return to the read mode (or to the erase-suspend-read mode if a sector was previously in the erase-suspend-program mode).

DQ3: Sector Erase Timeout State Indicator

After writing a sector erase command sequence, the output on DQ3 can be checked to determine whether or not an erase operation has begun. (The sector erase timer does not apply to the chip erase command.) When sector erase starts, DQ3 switches from “0” to “1”. This device does not support multiple sector erase (continuous sector erase) command sequences so it is not very meaningful since it immediately shows as a “1” after the first 30h command. Future devices may support this feature.

DQ1: Write to Buffer Abort

DQ1 indicates whether a Write to Buffer operation was aborted. Under these conditions DQ1 produces a “1”. The system must issue the “Write to Buffer Abort Reset” command sequence to return the device to reading array data.

Table 5. Write Operation Status

Status		DQ7 (note 2)	DQ6	DQ5 (note 1)	DQ3	DQ2 (note 2)	DQ1	RY/BY#	
Standard Mode	Embedded Program Algorithm	DQ7#	Toggle	0	N/A	No Toggle	0	0	
	Embedded Erase Algorithm	0	Toggle	0	1	Toggle	N/A	0	
Program Suspend Mode	Program Suspend Sector	Invalid (Not allowed)						1	
	Program Suspend Read	Data						1	
Erase Suspend Mode	Erase Suspend Read	Erase Suspend Sector	1	No Toggle	0	N/A	Toggle	N/A	1
		Non-Erase Suspend Sector	Data						0
	Erase Suspend Program (Embedded Program)	DQ7#	Toggle	0	N/A	N/A	N/A	0	
Write to Buffer	Busy(note 3)	DQ7#	Toggle	0	N/A	N/A	0	0	
	Abort(note 4)	DQ7#	Toggle	0	N/A	N/A	1	0	

Notes

1. DQ5 switches to 1 when an Embedded Program, Embedded Erase, or Write-to-Buffer operation has exceeded the maximum timing limits.
2. DQ7 and DQ2 require a valid address when reading status information. Refer to the appropriate subsection for further details.
3. The Data# Polling algorithm should be used to monitor the last loaded write-buffer address location.
4. DQ1 switches to 1 when the device has aborted the write-to-buffer operation

Writing Commands/Command Sequences

During a write operation, the system must drive CE# and WE# to VIL and OE# to VIH when providing an address, command, and data. Addresses are latched on the last falling edge of WE# or CE#, while data is latched on the 1st rising edge of WE# or CE#. An erase operation can erase one sector or the



entire device. Table 3 indicate the address space that each sector occupies. The device address space is divided into uniform 64KW/128KB sectors. A sector address is the set of address bits required to uniquely select a sector. ICC2 in “DC Characteristics” represents the active current specification for the write mode. “AC Characteristics” contains timing specification tables and timing diagrams for write operations.

RY/BY#

The RY/BY# is a dedicated, open-drain output pin that indicates whether an Embedded Algorithm is in progress or complete. The RY/BY# status is valid after the rising edge of the final WE# pulse in the command sequence. Since RY/BY# is an open-drain output, several RY/BY# pins can be tied together in parallel with a pull-up resistor to V_{CC} . This feature allows the host system to detect when data is ready to be read by simply monitoring the RY/BY# pin, which is a dedicated output and controlled by CE# (not OE#).

Hardware Reset

The RESET# input provides a hardware method of resetting the device to reading array data. When RESET# is driven low for at least a period of tRP (RESET# Pulse Width), the device immediately terminates any operation in progress, tristates all outputs, resets the configuration register, and ignores all read/write commands for the duration of the RESET# pulse. The device also resets the internal state machine to reading array data.

To ensure data integrity Program/Erase operations that were interrupted should be reinitiated once the device is ready to accept another command sequence.

When RESET# is held at VSS, the device draws V_{CC} reset current (ICC5). If RESET# is held at VIL, but not at VSS, the standby current is greater. RESET# may be tied to the system reset circuitry which enables the system to read the boot-up firmware from the Flash memory upon a system reset.

Software Reset

Software reset is part of the command set that also returns the device to array read mode and must be used for the following conditions:

1. To exit Autoselect mode
2. When DQ5 goes high during write status operation that indicates program or erase cycle was not successfully completed
3. Exit sector lock/unlock operation.
4. To return to erase-suspend-read mode if the device was previously in Erase Suspend mode.
5. After any aborted operations

The following are additional points to consider when using the reset command:

- This command resets the sectors to the read and address bits are ignored.
- Reset commands are ignored during program and erase operations.
- The reset command may be written between the cycles in a program command sequence before programming begins (prior to the third cycle). This resets the sector to which the system was writing to the read mode.
- If the program command sequence is written to a sector that is in the Erase Suspend mode, writing the reset command returns that sector to the erase-suspend-read mode.
- The reset command may be written during an Autoselect command sequence.
- If a sector has entered the Autoselect mode while in the Erase Suspend mode, writing the reset command returns that sector to the erase-suspend-read mode.
- If DQ1 goes high during a Write Buffer Programming operation, the system must write the “Write to Buffer Abort Reset” command sequence to RESET the device to reading array data. The standard RESET command does not work during this condition.

Advanced Sector Protection/Unprotection

The Advanced Sector Protection/Unprotection feature disables or enables programming or erase operations in any or all sectors and can be implemented through software and/or hardware methods, which are independent of each other. This section describes the various methods of protecting data stored in the memory array. An overview of these methods is shown in Figure 7.

Figure 7. Advanced Sector Protection/Unprotection

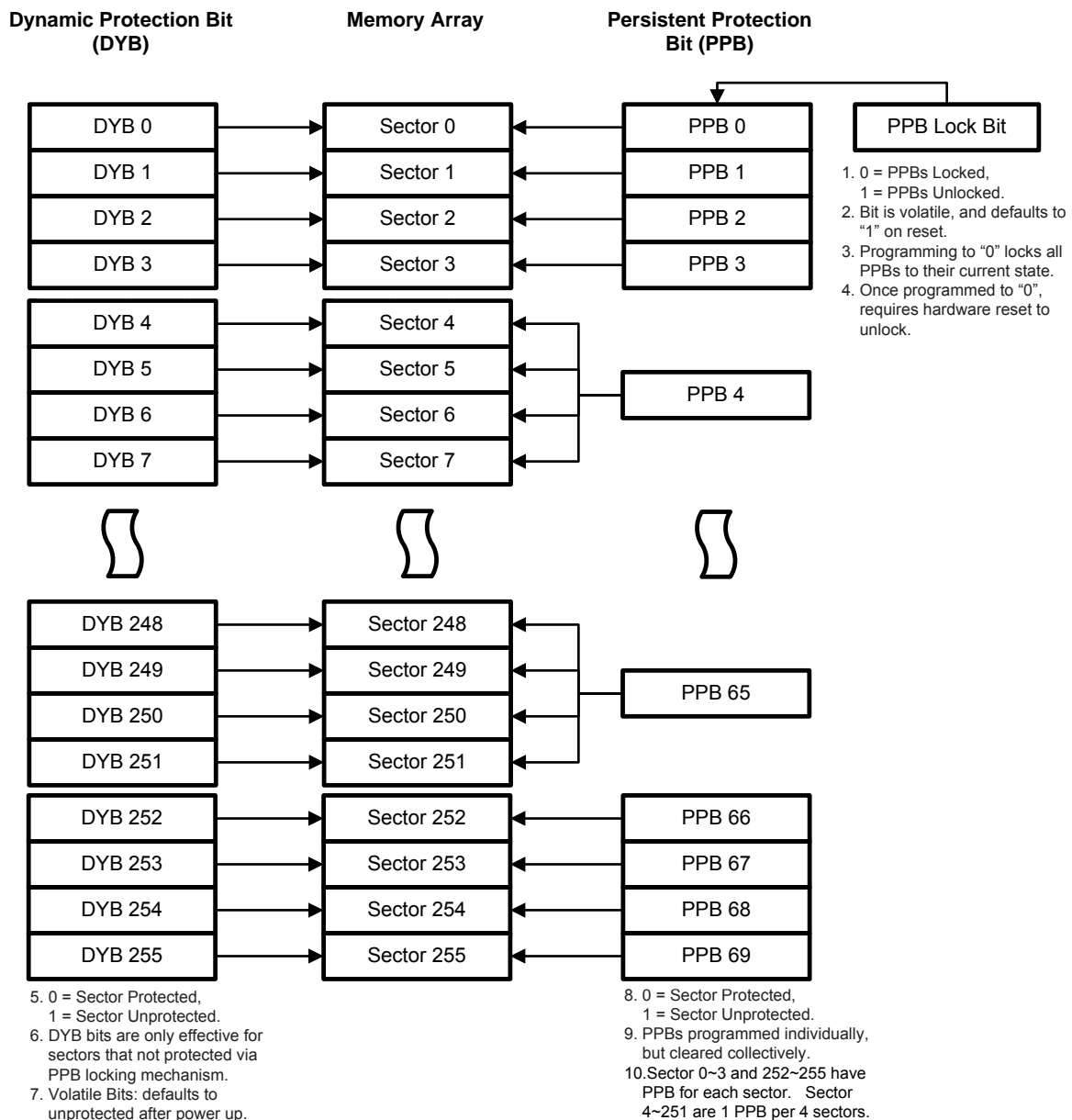

Lock Register

The Lock Register consists of 4 bits. The Secured Silicon Sector Protection Bit is DQ0, Persistent Protection Mode Lock Bit is DQ1, Persistent Sector Protection OTP bit is DQ3 and DYB Lock Boot Bit is DQ4. If DQ0 is '0', it means that the Customer Secured Silicon area is locked and if DQ0 is '1', it means



that it is unlocked. When DQ1 is set to '0', the device is used in the Persistent Protection Mode. DQ3 is programmed in the EON factory. When the device is programmed to disable all PPB erase command, DQ3 outputs a '0', when the lock register bits are read. Similarly, if the device is programmed to enable all PPB erase command, DQ3 outputs a '1' when the lock register bits are read. Likewise the DQ4 bit is also programmed in the EON Factory. DQ4 is the bit which indicates whether Volatile Sector Protection Bit (DYB) is protected or not after boot-up. When the device is programmed to set all Volatile Sector Protection Bit protected after power-up, DQ4 outputs a '0' when the lock register bits are read. Similarly, when the device is programmed to set all Volatile Sector Protection Bit unprotected after power-up, DQ4 outputs a '1'. Each of these bits in the lock register are non-volatile. DQ15- DQ5 are reserved and will be 1's.

Table 6. Lock Register

DQ15-5	DQ4	DQ3	DQ2	DQ1	DQ0
Reserved	DYB Lock Boot Bit	PPB One Time Programmable Bit	Reserved	Persistent Protection Mode Lock Bit	Secured Silicon Sector Protection Bit
(default = 1)	0 = protected all DYB after boot-up 1 = unprotected all DYB after boot-up (default = 1)	0 = All PPB Erase Command disabled 1 = All PPB Erase Command enabled (default = 1)	(default = 1)	0 = Persistent Protection enabled (default = 0)	0 = protected 1 = unprotect (default = 1)

Notes:

1. After the Lock Register Bits Command Set Entry command sequence is written, reads and writes for all Sector are disabled, while reads from other sectors are allowed until exiting this mode.
2. Only DQ0 could be change by Lock Register Bits Command for user. Others bits were set by Factory.

After selecting a sector protection method, each sector can operate in any of the following three states:

1. Constantly locked: The selected sectors are protected and can not be reprogrammed unless PPB lock bit is cleared via hardware reset, or power cycle.
2. Dynamically locked: The selected sectors are protected and can be altered via software commands.
3. Unlocked: The sectors are unprotected and can be erased and/or programmed.

Persistent Protection Bits

The Persistent Protection Bits are unique and nonvolatile. For Sector 0~3 and 252~255 have one PPB for each sectors and for Sector 4~251 have one PPB every four sectors (refer to Figure 7 and Table 3. Sector / Persistent Protection Sector Group Address Tables) and have the same endurances as the Flash memory. Preprogramming and verification prior to erasure are handled by the device, and therefore do not require system monitoring.

Notes

1. Each PPB is individually programmed and all are erased in parallel.
2. While programming PPB for the four sectors and Data polling on programming PPB address, array data can not be read from any sectors.
3. Entry command disables reads and writes for all sectors selected.
4. Reads within that sector return the PPB status for that sector.
5. All Reads must be performed using the read mode.
6. The specific sector address are written at the same time as the program command.
7. If the PPB Lock Bit is set, the PPB Program or erase command does not execute and times-out without programming or erasing the PPB.
8. There are no means for individually erasing a specific PPB and no specific sector address is required for this operation.
9. Exit command must be issued after the execution which resets the device to read mode and re-enables reads and writes for all sectors.
10. The programming state of the PPB for given sectors can be verified by writing a PPB Status Read Command to the device as described by the flow chart shown in Figure 8. User only can use DQ6 and RY/BY# pin to detect programming status.

Figure 8. PPB Program Algorithm

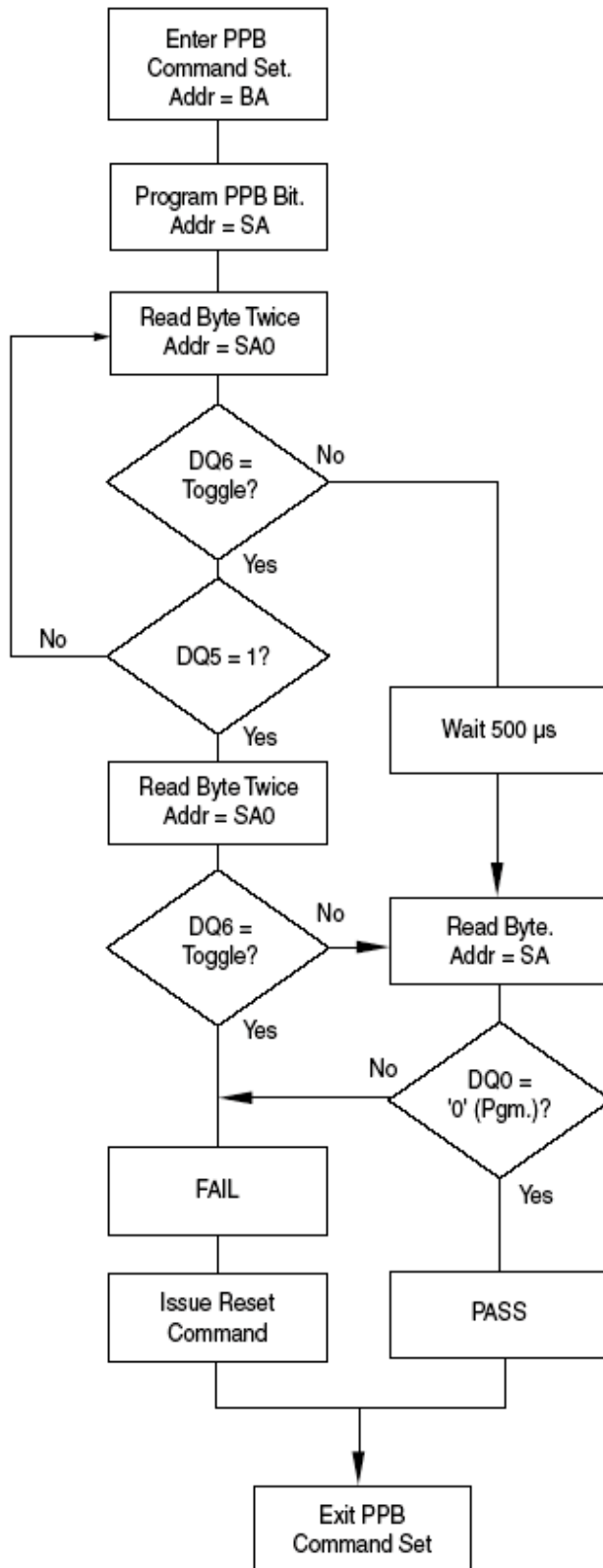

Note: BA = base address



Dynamic Protection Bits

Dynamic Protection Bits are volatile and unique for each sector and can be individually modified. DYBs only control the protection scheme for unprotected sectors that have their PPBs cleared (erased to “1”). By issuing the DYB Set or Clear command sequences, the DYBs are set (programmed to “0”) or cleared (erased to “1”), thus placing each sector in the protected or unprotected state respectively. This feature allows software to easily protect sectors against inadvertent changes yet does not prevent the easy removal of protection when changes are needed.

Notes

1. The DYBs can be set (programmed to “0”) or cleared (erased to “1”) as often as needed. When the parts are first shipped, the PPBs are cleared (erased to “1”) and upon power up or reset, the DYBs can be set or cleared depending upon the ordering option chosen.
2. If the option to clear the DYBs after power up is chosen, (erased to “1”), then the sectors may be modified depending upon the PPB state of that sector (see Table 7).
3. The sectors would be in the protected state if the option to set the DYBs after power up is chosen (programmed to “0”).
4. It is possible to have sectors that are persistently locked with sectors that are left in the dynamic state.
5. The DYB Set or Clear commands for the dynamic sectors signify protected or unprotected state of the sectors respectively. However, if there is a need to change the status of the persistently locked sectors, a few more steps are required. First, the PPB Lock Bit must be cleared by either putting the device through a power-cycle, or hardware reset. The PPBs can then be changed to reflect the desired settings. Setting the PPB Lock Bit once again locks the PPBs, and the device operates normally again.
6. To achieve the best protection, it is recommended to execute the PPB Lock Bit Set command early in the boot code and protect the boot code by holding $WP\#/ACC = VIL$. Note that the PPB and DYB bits have the same function when $WP\#/ACC = VHH$ as they do when $ACC = VIH$.

Persistent Protection Bit Lock Bit

The Persistent Protection Bit Lock Bit is a global volatile bit for all sectors. When set (programmed to “0”), it locks all PPBs and when cleared (erased to “1”), allows the PPBs to be changed. There is only one PPB Lock Bit per device.

Notes

1. No software command sequence unlocks this bit, but only a hardware reset or a power-up clears this bit.
2. The PPB Lock Bit must be set (programmed to “0”) only after all PPBs are configured to the desired settings.

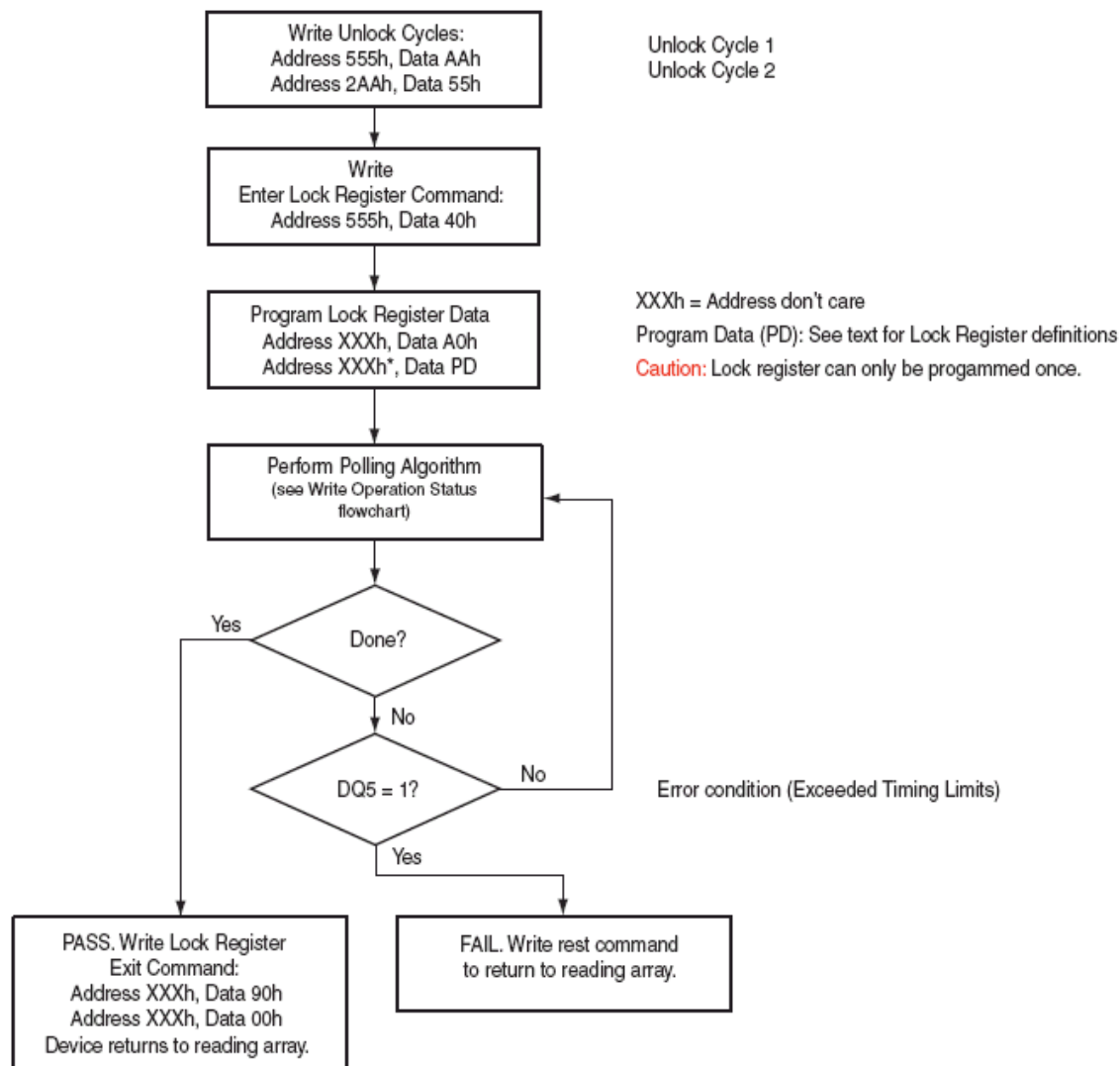
Figure 9. Lock Register Program Algorithm

Advanced Sector Protection Software Examples

Table 7. Sector Protection Schemes: DYB, PPB and PPB Lock Bit Combinations

Unique Device PPB Lock Bit 0 = locked 1 = unlocked	Sector PPB 0 = protected 1 = unprotected	Sector DYB 0 = protected 1 = unprotected	Sector Protection Status
Any Sector	0	x	Protected through PPB
Any Sector	0	0	Protected through PPB
Any Sector	0	1	Unprotected
Any Sector	0	0	Protected through DYB
Any Sector	1	x	Protected through PPB
Any Sector	1	0	Protected through PPB
Any Sector	1	1	Protected through DYB
Any Sector	1	1	Unprotected



Table 7 contains all possible combinations of the DYB, PPB, and PPB Lock Bit relating to the status of the sector. In summary, if the PPB Lock Bit is locked (set to “0”), no changes to the PPBs are allowed. The PPB Lock Bit can only be unlocked (reset to “1”) through a hardware reset or power cycle. See also Figure 7 for an overview of the Advanced Sector Protection feature.

Hardware Data Protection Methods

The device offers two main types of data protection at the sector level via hardware control:

- When WP#/ACC is at VIL, the either the highest or lowest sector is locked (device specific). There are additional methods by which intended or accidental erasure of any sectors can be prevented via hardware means. The following subsections describes these methods:

WP#/ACC Method

The Write Protect feature provides a hardware method of protecting one outermost sector. This function is provided by the WP#/ACC pin and overrides the previously discussed Sector Protection/Unprotection method.

If the system asserts VIL on the WP#/ACC pin, the device disables program and erase functions in the highest or lowest sector independently of whether the sector was protected or unprotected using the method described in Advanced Sector Protection/Unprotection on page 27.

If the system asserts VIH on the WP#/ACC pin, the device reverts to whether the boot sectors were last set to be protected or unprotected. That is, sector protection or unprotection for these sectors depends on whether they were last protected or unprotected.

The WP#/ACC pin must be held stable during a command sequence execution. WP# has an internal pull-up; when unconnected, WP# is set at VIH.

Note

If WP#/ACC is at VIL when the device is in the standby mode, the maximum input load current is increased.

Low V_{CC} Write Inhibit

When V_{CC} is less than VLKO, the device does not accept any write cycles. This protects data during V_{CC} power-up and power-down.

The command register and all internal program/erase circuits are disabled, and the device resets to reading array data. Subsequent writes are ignored until V_{CC} is greater than VLKO. The system must provide the proper signals to the control inputs to prevent unintentional writes when V_{CC} is greater than VLKO.

Write Pulse “Glitch Protection”

Noise pulses of less than 5 ns (typical) on OE#, CE# or WE# do not initiate a write cycle.

Power-Up Write Inhibit

If WE# = CE# = RESET# = VIL and OE# = VIH during power up, the device does not accept commands on the rising edge of WE#. The internal state machine is automatically reset to the read mode on power-up.



Power Conservation Modes

Standby Mode

When the system is not reading or writing to the device, it can place the device in the standby mode. In this mode, current consumption is greatly reduced, and the outputs are placed in the high impedance state, independent of the OE# input. The device enters the CMOS standby mode when the CE# and RESET# inputs are both held at $V_{CC} \pm 0.3$ V. The device requires standard access time (tCE) for read access, before it is ready to read data. If the device is deselected during erasure or programming, the device draws active current until the operation is completed. ICC4 in “DC Characteristics” represents the standby current specification

Automatic Sleep Mode

The automatic sleep mode minimizes Flash device energy consumption. The device automatically enables this mode when addresses remain stable for tACC + 30 ns. The automatic sleep mode is independent of the CE#, WE#, and OE# control signals. Standard address access timings provide new data when addresses are changed. While in sleep mode, output data is latched and always available to the system.

Hardware RESET# Input Operation

The RESET# input provides a hardware method of resetting the device to reading array data. When RESET# is driven low for at least a period of tRP, the device immediately terminates any operation in progress, tristates all outputs, and ignores all read/write commands for the duration of the RESET# pulse. The device also resets the internal state machine to reading array data. The operation that was interrupted should be reinitiated once the device is ready to accept another command sequence to ensure data integrity.

When RESET# is held at $V_{SS} \pm 0.3$ V, the device draws ICC reset current (ICC5). If RESET# is held at VIL but not within $V_{SS} \pm 0.3$ V, the standby current is greater.

RESET# may be tied to the system reset circuitry and thus, a system reset would also reset the Flash memory, enabling the system to read the boot-up firmware from the Flash memory.

Output Disable (OE#)

When the OE# input is at VIH, output from the device is disabled. The outputs are placed in the high impedance state. (With the exception of RY/BY#.)

Secured Silicon Sector Flash Memory Region

The Secured Silicon Sector provides an extra Flash memory region. The Secured Silicon Sector is 128 words in length and all Secured Silicon reads outside of the 128-word address range returns invalid data. The Secured Silicon Sector Indicator Bit, DQ7, (at Autoselect address 03h) is used to indicate whether or not the Secured Silicon Sector is locked when shipped from the factory.

Please note the following general conditions:

- On power-up, or following a hardware reset, the device reverts to sending commands to the normal address space.
- Reads outside of sector SA0 return memory array data.
- Sector SA0 is remapped from memory array to Secured Silicon Sector array.
- Once the Secured Silicon Sector Entry Command is issued, the Secured Silicon Sector Exit command must be issued to exit Secured Silicon Sector Mode.
- The Secured Silicon Sector is not accessible when the device is executing an Embedded Program or Embedded Erase algorithm.
- When sector SA0 is suspended, if system enters Secured Silicon Sector mode, the Secured Silicon Sector Region cannot be read. If the system suspends the flash in other sectors except SA0, Secured Silicon Sector Region can be read normally.



- The ACC function is not available when the Secured Silicon Sector is enabled.

Table 8. Secured Silicon Sector Addresses

Secured Silicon Sector Address Range	
000000h-000007h	Reserve for Factory
000008h-00007Fh	Determined by customer

Customer Lockable Secured Silicon Sector

The Customer Lockable Secured Silicon Sector is always shipped unprotected (DQ0 set to “1”), allowing customers to utilize that sector in any manner they choose. If the security feature is not required, the Secured Silicon Sector can be treated as an additional Flash memory space.

Please note the following:

- Once the Secured Silicon Sector area is protected, the Secured Silicon Sector Indicator Bit (DQ0) is permanently set to “0.”
- The Secured Silicon Sector can be read any number of times, but can be programmed and locked only once. The Secured Silicon Sector lock must be used with caution as once locked, there is no procedure available for unlocking the Secured Silicon Sector area and none of the bits in the Secured Silicon Sector memory space can be modified in any way.
- The accelerated programming (ACC) is not available when the Secured Silicon Sector is enabled.
- Once the Secured Silicon Sector is locked and verified, the system must write the Exit Secured Silicon Sector Region command sequence which return the device to the memory array at sector 0.
- The address 0h~7h in Secured Silicon Sector is reserved for Factory.

Secured Silicon Sector Entry/Exit Command Sequences

The system can access the Secured Silicon Sector region by issuing the three-cycle Enter Secured Silicon Sector command sequence. The device continues to access the Secured Silicon Sector region until the system issues the four-cycle Exit Secured Silicon Sector command sequence.

The Secured Silicon Sector Entry Command allows the following commands to be executed

- Read customer and factory Secured Silicon areas
- Program the customer Secured Silicon Sector

After the system has written the Enter Secured Silicon Sector command sequence, it may read the Secured Silicon Sector by using the addresses normally occupied by sector SA0 within the memory array. This mode of operation continues until the system issues the Exit Secured Silicon Sector command sequence, or until power is removed from the device.



COMMON FLASH INTERFACE (CFI)

The common flash interface (CFI) specification outlines device and host systems software interrogation handshake, which allows specific vendor-specified software algorithms to be used for entire families of devices. Software support can then be device-independent, JEDEC ID-independent, and forward- and backward-compatible for the specified flash device families. Flash vendors can standardize their existing interfaces for long-term compatibility.

This device enters the CFI Query mode when the system writes the CFI Query command, 98h, to address 55h in word mode (or address AAh in byte mode), any time the device is ready to read array data.

The system can read CFI information at the addresses given in Tables 9~12. In word mode, the upper address bits (A7-MSB) must be all zeros. To terminate reading CFI data, the system must write the reset command.

The system can also write the CFI query command when the device is in the autoselect mode. The device enters the CFI query mode and the system can read CFI data at the addresses given in Tables 9~12. The system must write the reset command to return the device to the autoselect mode.



Table 9. CFI Query Identification String

Addresses (Word Mode)	Data	Description
10h 11h 12h	0051h 0052h 0059h	Query Unique ASCII string "QRY"
13h 14h	0002h 0000h	Primary OEM Command Set
15h 16h	0040h 0000h	Address for Primary Extended Table
17h 18h	0000h 0000h	Alternate OEM Command set (00h = none exists)
19h 1Ah	0000h 0000h	Address for Alternate OEM Extended Table (00h = none exists)

Table 10. System Interface String

Addresses (Word Mode)	Data	Description
1Bh	0027h	Vcc Min (write/erase) DQ7-DQ4: volt, DQ3-DQ0: 100mV
1Ch	0036h	Vcc Max (write/erase) DQ7-DQ4: volt, DQ3-DQ0: 100mV
1Dh	0000h	Vpp Min voltage (00h = no Vpp pin present)
1Eh	0000h	Vpp Max voltage (00h = no Vpp pin present)
1Fh	0003h	Typical timeout per single byte/word write 2^N μ s
20h	0004h	Typical timeout for min size buffer write 2^N μ s (00h = not supported)
21h	0009h	Typical timeout per individual block erase 2^N ms
22h	0000h	Typical timeout for full chip erase 2^N ms (00h = not supported)
23h	0005h	Max timeout for byte/word write 2^N times typical
24h	0005h	Max timeout for buffer write 2^N times typical
25h	0004h	Max timeout per individual block erase 2^N times typical
26h	0000h	Max timeout for full chip erase 2^N times typical (00h = not supported)

Table 11. Device Geometry Definition

Addresses (Word mode)	Data	Description
27h	0019h	Device Size = 2^N bytes. $2^{**25}=32\text{MB}=256\text{Mb}$
28h 29h	0002h 0000h	Flash Device Interface Description (refer to CFI publication 100); 01h = X16 only; 02h = x8/x16
2Ah 2Bh	0006h 0000h	Max number of byte in multi-byte write = 2^N (00h = not supported)
2Ch	0001h	Number of Erase Block Regions within device
2Dh 2Eh 2Fh 30h	00FFh 0000h 0000h 0002h	Erase Block Region 1 Information (refer to the CFI specification of CFI publication 100) 256 uniform sectors (7Fh + 1)
31h 32h 33h 34h	0000h 0000h 0000h 0000h	Erase Block Region 3 Information (refer to the CFI specification of CFI publication 100)
35h 36h 37h 38h	0000h 0000h 0000h 0000h	Erase Block Region 3 Information (refer to the CFI specification of CFI publication 100)



39h	0000h	Erase Block Region 4 Information (refer to the CFI specification of CFI publication 100)
3Ah	0000h	
3Bh	0000h	
3Ch	0000h	

Table 12. Primary Vendor-specific Extended Query

Addresses (Word Mode)	Data	Description
40h 41h 42h	0050h 0052h 0049h	Query Unique ASCII string "PRI"
43h	0031h	Major version number, ASCII
44h	0034h	Minor version number, ASCII
45h	000Ch	Address Sensitive Unlock (Bits 1-0) 00 = Required, 01 = Not Required Technology (Bits 5-2) 0001 = 0.18um, 0010 = 0.13um, 0011 = 90nm
46h	0002h	Erase Suspend 0 = Not Supported, 1 = To Read Only, 2 = To Read & Write
47h	0001h	Sector Protect 0 = Not Supported, X = Minimum number of sectors per group
48h	0000h	Sector Temporary Unprotect 00 = Not Supported, 01 = Supported
49h	0003h	Sector Protect/Unprotect Scheme 00h = High Voltage Sector Protection 01h = High Voltage + In-System Sector Protection 02h = HV + In-System + Software Command Sector Protection 03h = Software Command Sector Protection
4Ah	0000h	Simultaneous Operation 00 = Not Supported, X = Number of Sectors
4Bh	0000h	Burst Mode Type 00 = Not Supported, 01 = Supported
4Ch	0002h	Page Mode Type 00 = Not Supported, 01 = 4 Word Page, 02 = 8 Word Page
4Dh	0085h	Minimum WP#/ACC (Acceleration) Supply Voltage 00 = Not Supported, DQ7-DQ4: Volts, DQ3=DQ0: 100mV
4Eh	0095h	Maximum WP#/ACC (Acceleration) Supply Voltage 00 = Not Supported, DQ7-DQ4: Volts, DQ3=DQ0: 100mV
4Fh	00xxh	Top/Bottom Boot Sector Flag 04 = Uniform sectors bottom WP# protect 05 = Uniform sectors top WP# protect
50h	0001h	Program Suspend 00 = Not Supported, 01 = Supported
52h	0008h	Secured Silicon Sector (Customer OTP Area) Size 2 ^N bytes
53h	000Fh	Hardware Reset Low Time-out during an embedded algorithm to read mode Maximum 2 ^N ns
54h	0009h	Hardware Reset Low Time-out not during an embedded algorithm to read mode Maximum 2 ^N ns
55h	0005h	Erase Suspend Latency Maximum 2 ^N μs
56h	0005h	Program Suspend Latency Maximum 2 ^N μs
57h	0000h	Bank Organization 00 = Data at 4Ah is zero, X = Number of Banks



Table 13. EN29GL256 Command Definitions

Command Sequence		Cycles	Bus Cycles												
			1 st Cycle		2 nd Cycle		3 rd Cycle		4 th Cycle		5 th Cycle		6 th Cycle		
			Addr	Data	Addr	Data	Addr	Data	Addr	Data	Addr	Data	Addr	Data	
Read		1	RA	RD											
Reset		1	XXX	F0											
Autoselect	Manufacturer ID	Word	4	555	AA	2AA	55	555	90	000	7F				
		Byte	4	AAA	AA	555	55	AAA	90	100	1C				
	Device ID	Word	4	555	AA	2AA	55	555	90	X01	227E	X0E	2222	X0F	2201
		Byte	4	AAA	AA	555	55	AAA	90	X02	7E	X1C	22	X1E	01
	Sector Protect Verify	Word	4	555	AA	2AA	55	555	90	(SA)	00				
		Byte	4	AAA	AA	555	55	AAA	90	X02	01				
Program		Word	4	555	AA	2AA	55	555	A0	PA	PD				
		Byte	4	AAA	AA	555	55	AAA	A0	PA	PD				
Write to Buffer		Word	6	555	AA	2AA	55	SA	25	SA	WC	PA	PD	WBL	PD
		Byte	6	AAA	AA	555	55	SA	25	SA	WC	PA	PD	WBL	PD
Program Buffer to Flash		Word	1	SA	29										
		Byte	1	SA	29										
Write to Buffer Abort Reset		Word	3	555	AA	2AA	55	555	F0						
		Byte	3	AAA	AA	555	55	AAA	F0						
Chip Erase		Word	6	555	AA	2AA	55	555	80	555	AA	2AA	55	555	10
		Byte	6	AAA	AA	555	55	AAA	80	AAA	AA	555	55	AAA	10
Sector Erase		Word	6	555	AA	2AA	55	555	80	555	AA	2AA	55	SA	30
		Byte	6	AAA	AA	555	55	AAA	80	AAA	AA	555	55	SA	30
Erase/Program Suspend		1	XXX	B0											
Erase/Program Resume		1	XXX	30											
Secured Silicon Sector Entry		3	555	AA	2AA	55	555	88							
Secured Silicon Sector Exit		4	555	AA	2AA	55	555	90	XX	00					
CFI Query		Word	1	55	98										
		Byte	1	AA	98										
Accelerated Program		2	XX	A0	PA	PD									

Legend

X = Don't care

RA = Address of the memory to be read.

RD = Data read from location RA during read operation.

PA = Address of the memory location to be programmed. Addresses latch on the falling edge of the WE# or CE# pulse, whichever happens later.

PD = Data to be programmed at location PA. Data latches on the rising edge of the WE# or CE# pulse, whichever happens first.

SA = Address of the sector to be verified (in autoselect mode) or erased. Address bits Amax–A16 uniquely select any sector.

WBL = Write Buffer Location. The address must be within the same write buffer page as PA.

WC = Word Count is the number of write buffer locations to load minus 1 and maximum value is 31 for word and byte mode.



Table 14. EN29GL256 Command Definitions

Command Sequence			Cycles	Bus Cycles											
				1 st Cycle		2 nd Cycle		3 rd Cycle		4 th Cycle		5 th Cycle		6 th Cycle	
				Addr	Data	Addr	Data	Addr	Data	Addr	Data	Addr	Data	Addr	Data
Lock Register	Command Set Entry	Word	3	555	AA	2AA	55	555	40						
		Byte	3	AAA	AA	55	55	AAA	40						
	Program		2	XXX	A0	XXX	Data								
	Read		1	00	RD										
	Command Set Exit		2	XXX	90	XXX	00								
Global Non-Volatile	PPB Command Set Entry	Word	3	555	AA	2AA	55	555	C0						
		Byte	3	AAA	AA	55	55	AAA	C0						
	PPB Program		2	XXX	A0	SA	00								
	All PPB Erase		2	XXX	80	00	30								
	PPB Status Read		1	SA	RD										
PPB Command Set Exit		2	XXX	90	XXX	00									
Global Volatile Freeze	PPB Lock Command Set Entry	Word	3	555	AA	2AA	55	555	50						
		Byte	3	AAA	AA	555	55	AAA	50						
	PPB Lock Set		2	XXX	A0	XXX	00								
	PPB Lock Status Read		1	XXX	RD										
	PPB Lock Command Set Exit		2	XXX	90	XXX	00								
Volatile	DYB Command Set Entry	Word	3	555	AA	2AA	55	555	E0						
		Byte	3	AAA	AA	555	55	AAA	E0						
	DYB Set		2	XXX	A0	SA	00								
	DYB Clear		2	XXX	A0	SA	01								
	DYB Status Read		1	SA	RD										
DYB Command Set Exit		2	XXX	90	XXX	00									

Legend

- X = Don't care
- RD(0) = Read data.
- SA = Sector Address. Address bits Amax–A16 uniquely select any sector.
- PWD = Password
- PWDx = Password word0, word1, word2, and word3.
- Data = Lock Register Contents: PD(0) = Secured Silicon Sector Protection Bit,
- PD(1) = Persistent Protection Mode Lock Bit, PD(2) = Password Protection Mode Lock Bit.



Table 15. DC Characteristics

($T_a = -40^{\circ}\text{C}$ to 85°C ; $V_{CC} = 2.7\text{-}3.6\text{V}$)

Symbol	Parameter	Test Conditions	Min	Typ	Max	Unit	
I_{LI}	Input Leakage Current	$0\text{V} \leq V_{IN} \leq V_{CC}$			± 5	μA	
I_{LO}	Output Leakage Current	$0\text{V} \leq V_{OUT} \leq V_{CC}$			± 1	μA	
I_{CC1}	V_{CC} Active Read Current	CE# = V_{IL} ; OE# = V_{IH} ; $V_{CC} = V_{CC\text{max}}$		5MHz	15	30	mA
				10MHz	25	45	
I_{IO2}	V_{IO} Non-Active Output	CE# = V_{IL} , OE# = V_{IH}		0.2	10	mA	
I_{CC2}	V_{CC} Intra-Page Read Current	CE# = V_{IL} , OE# = V_{IH} , $V_{CC} = V_{CC\text{max}}$, $f = 10\text{MHz}$ CE# = V_{IL} , OE# = V_{IH} , $V_{CC} = V_{CC\text{max}}$, $f = 33\text{MHz}$		1	10	mA	
				5	15		
I_{CC3}	V_{CC} Active Erase/Program Current	CE# = V_{IL} , OE# = V_{IH} , $V_{CC} = V_{CC\text{max}}$		20	30	mA	
I_{CC4}	V_{CC} Standby Current	CE#, RESET# = $V_{CC} \pm 0.3\text{V}$, OE# = V_{IH} , $V_{CC} = V_{CC\text{max}}$ $V_{IL} = V_{SS} + 0.3\text{V}/-0.1\text{V}$,		1.5	10	μA	
I_{CC5}	V_{CC} Reset Current	RESET# = $V_{SS} \pm 0.3\text{V}$		1.5	10	μA	
I_{CC6}	Automatic Sleep Mode	$V_{IH} = V_{CC} \pm 0.3\text{V}$ $V_{IL} = V_{SS} \pm 0.3\text{V}$		1.5	10	μA	
I_{ACC}	ACC Accelerated Program Current	CE# = V_{IL} , OE# = V_{IH} , $V_{CC} = V_{CC\text{max}}$, WP#/ACC = V_{HH}	WP#/ACC pin	3	10	mA	
			VCC pin	15	30		
V_{IL}	Input Low Voltage		-0.5		$0.3 \times V_{IO}$	V	
V_{IH}	Input High Voltage		$0.7 \times V_{IO}$		$V_{IO} + 0.3$	V	
V_{HH}	Acceleration Program Voltage		8.5		9.5	V	
V_{OL}	Output Low Voltage	$I_{OL} = 100\mu\text{A}$			$0.15 \times V_{IO}$	V	
V_{OH}	Output High Voltage CMOS	$I_{OH} = -100\mu\text{A}$	$0.85 \times V_{IO}$			V	
V_{LKO}	Supply voltage (Erase and Program lock-out)		2.3		2.5	V	

Notes:

1. BYTE# pin can also be $\text{GND} \pm 0.3\text{V}$. BYTE# and RESET# pin input buffers are always enabled so that they draw power if not at full CMOS supply voltages.
2. Maximum I_{CC} specifications are tested with $V_{CC} = V_{CC\text{max}}$.
3. Not 100% tested.

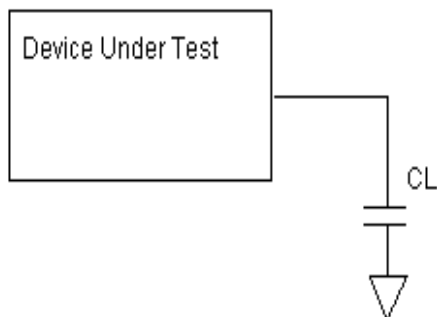
Figure 10. Test Conditions

Table 16. Test Specifications

Test Conditions	-90	Unit
Output Load Capacitance, C_L	100	pF
Input Rise and Fall times	5	ns
Input Pulse Levels	0.0-3.0	V
Input timing measurement reference levels	1.5	V
Output timing measurement reference levels	1.5	V



AC CHARACTERISTICS

Table 17. Read-only Operations Characteristics

Parameter Symbols		Description	Test Setup		Speed	Unit
JEDEC	Standard				-90	
t_{AVAV}	t_{RC}	Read Cycle Time		Min	90	ns
t_{AVQV}	t_{ACC}	Address to Output Delay	CE# = V_{IL} OE# = V_{IL}	Max	90	ns
t_{ELQV}	t_{CE}	Chip Enable To Output Delay	OE# = V_{IL}	Max	90	ns
	t_{PACC}	Page Access Time		Max	25	ns
t_{GLQV}	t_{OE}	Output Enable to Output Delay		Max	35	ns
t_{EHQZ}	t_{DF}	Chip Enable to Output High Z		Max	20	ns
t_{GHQZ}	t_{DF}	Output Enable to Output High Z		Max	20	ns
t_{AXQX}	t_{OH}	Output Hold Time from Addresses, CE# or OE#, whichever occurs first		Min	0	ns
	t_{OEHL}	Output Enable Hold Time	Read	Min	0	ns
			Toggle and DATA# Polling	Min	10	ns

Notes:

- High Z is Not 100% tested.
- For -90
 - $V_{CC} = 2.7V - 3.6V$
 - Output Load : 1 TTL gate and 100pF
 - Input Rise and Fall Times: 5ns
 - Input Rise Levels: 0.0 V to 3.0 V
 - Timing Measurement Reference Level, Input and Output: 1.5 V

Figure 10. AC Waveforms for READ Operations

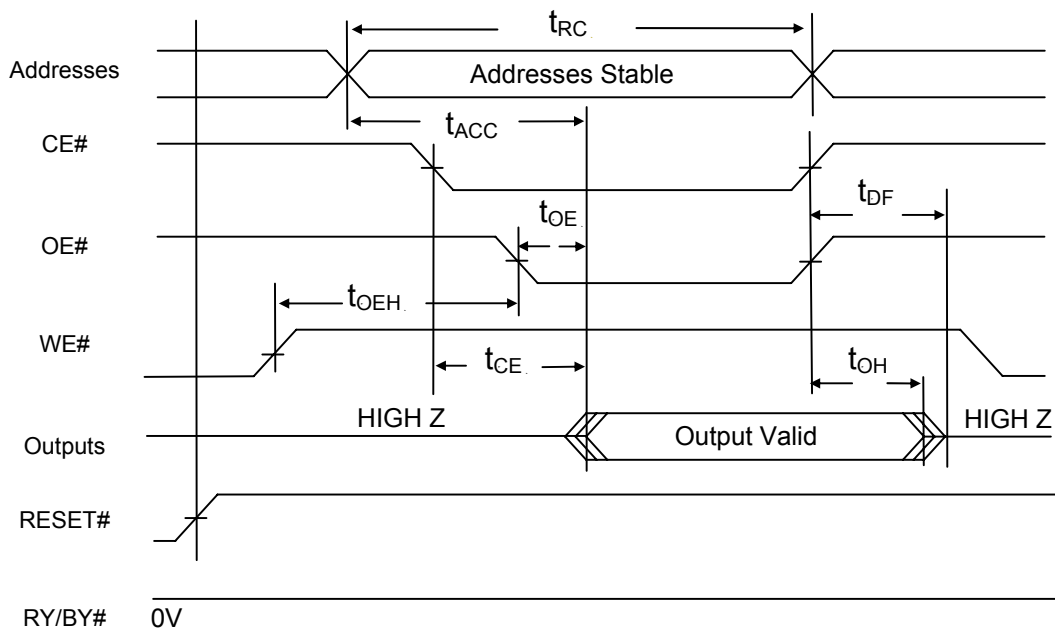
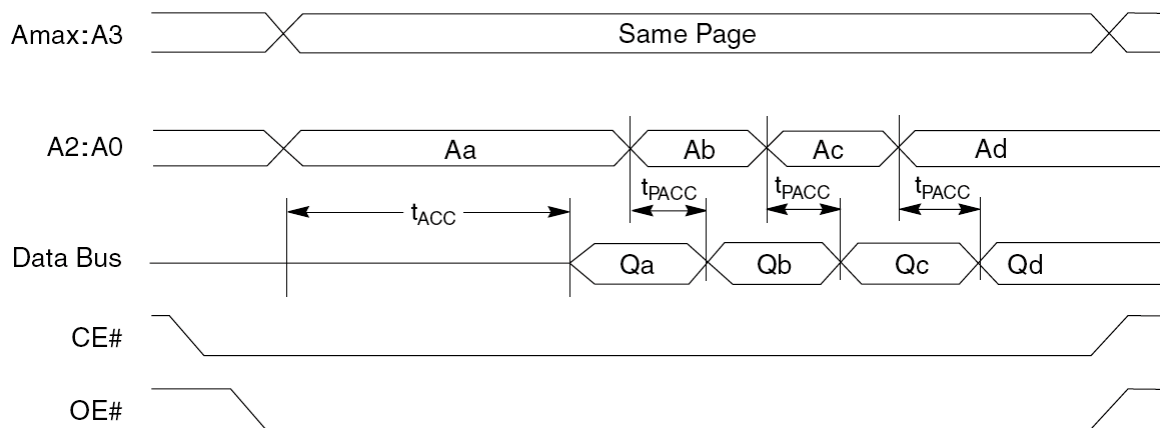

Figure 11. Page Read Operation Timings

Note: Addresses are A2:A-1 for byte mode.



AC CHARACTERISTICS

Table 18. Hardware Reset (RESET#)

Parameter Std	Description	Test Setup	Speed	Unit
			-90	
t_{RP1}	RESET# Pulse Width (During Embedded Algorithms)	Min	10	us
t_{RP2}	RESET# Pulse Width (NOT During Embedded Algorithms)	Min	500	ns
t_{RH}	Reset# High Time Before Read	Min	50	ns
t_{RB1}	RY/BY# Recovery Time (to CE#, OE# go low)	Min	0	ns
t_{RB2}	RY/BY# Recovery Time (to WE# go low)	Min	50	ns
t_{READY1}	Reset# Pin Low (During Embedded Algorithms) to Read or Write	Max	20	us
t_{READY2}	Reset# Pin Low (NOT During Embedded Algorithms) to Read or Write	Max	500	ns

Figure 12. AC Waveforms for RESET#
Reset# Timings

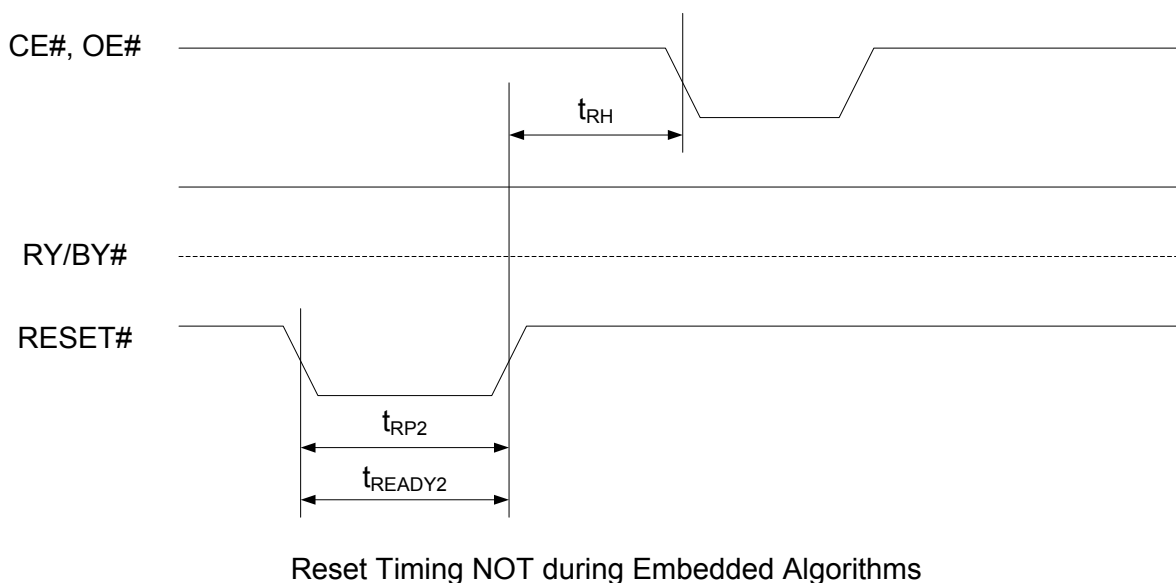
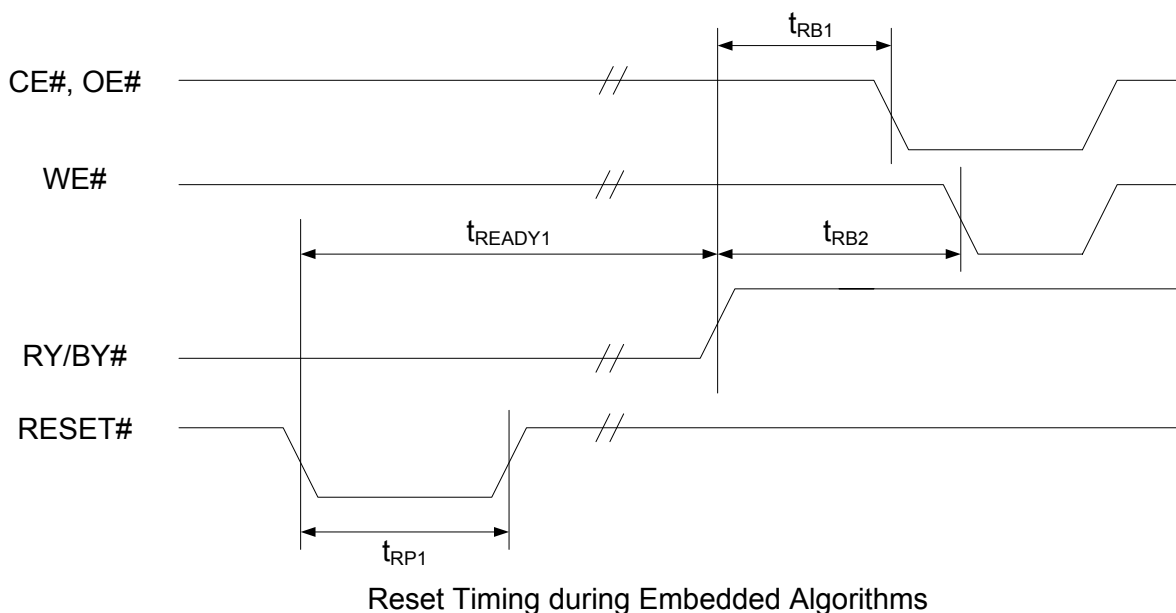

AC CHARACTERISTICS
Table 19. Word / Byte Configuration (BYTE#)

Std Parameter	Description	Test Setup	Speed	Unit
			-90	
t_{BCS}	Byte# to CE# switching setup time	Min	0	ns
t_{CBH}	CE# to Byte# switching hold time	Min	0	ns
t_{RBH}	RY/BY# to Byte# switching hold time	Min	0	ns

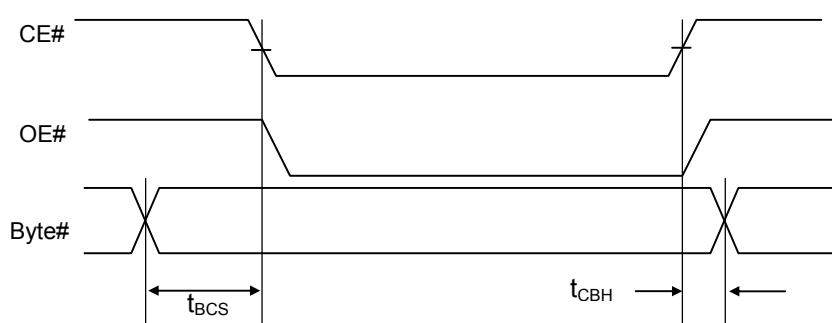
Figure 13. AC Waveforms for BYTE#

Byte# timings for Read Operations

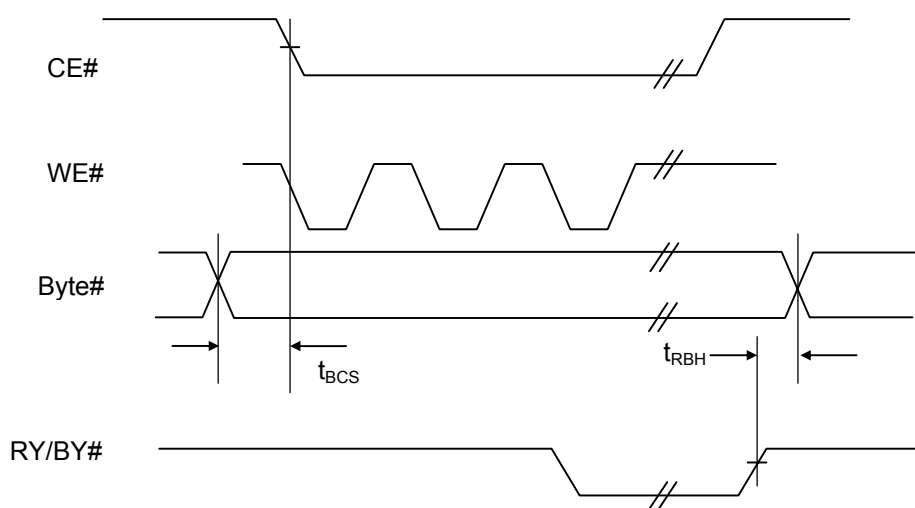

Byte #timings for Write Operations

Note: Switching BYTE# pin not allowed during embedded operations



AC CHARACTERISTICS

Table 20. Write (Erase/Program) Operations

Parameter Symbols		Description		Speed	Unit	
JEDEC	Standard			-90		
t_{AVAV}	t_{WC}	Write Cycle Time	Min	90	ns	
t_{AVWL}	t_{AS}	Address Setup Time	Min	0	ns	
t_{WLAX}	t_{AH}	Address Hold Time	Min	45	ns	
t_{DVWH}	t_{DS}	Data Setup Time	Min	40	ns	
t_{WHDX}	t_{DH}	Data Hold Time	Min	0	ns	
	t_{OEHL}	Output Enable Hold Time	Read	Min	0	ns
			Toggle and DATA# Polling	Min	10	ns
t_{GHWL}	t_{GHWL}	Read Recovery Time before Write (OE# High to WE# Low)	Min	0	ns	
t_{ELWL}	t_{CS}	CE# Setup Time	Min	0	ns	
t_{WHEH}	t_{CH}	CE# Hold Time	Min	0	ns	
t_{WLWH}	t_{WP}	Write Pulse Width	Min	35	ns	
t_{WHDL}	t_{WPH}	Write Pulse Width High	Min	25	ns	
t_{WHWH1}	t_{WHWH1}	Write Buffer Program Operation (Note 2, 3)	Typ	160	μ s	
		Programming Operation (Word AND Byte Mode)	Typ	8	μ s	
			Max	200	μ s	
t_{WHWH2}	t_{WHWH2}	Sector Erase Operation	Typ	0.1	s	
			Max	2	s	
		Chip Erase Operation	Typ	60	s	
	t_{VHH}	V_{HH} Rise and Fall Time	Min	250	ns	
	t_{VCS}	Vcc Setup Time	Min	50	μ s	
	t_{BUSY}	WE# High to RY/BY# Low	Max	90	ns	
	t_{RB}	Recovery Time from RY/BY#	Min	0	ns	

Notes: 1. Not 100% tested.

2. See table.22 Erase and Programming Performance for more information.

3. For 1~32 words bytes programmed.



AC CHARACTERISTICS

Table 21. Write (Erase/Program) Operations

Alternate CE# Controlled Writes

Parameter Symbols		Description		Speed	Unit
JEDEC	Standard			-90	
t_{AVAV}	t_{WC}	Write Cycle Time	Min	90	ns
t_{AVEL}	t_{AS}	Address Setup Time	Min	0	ns
t_{ELAX}	t_{AH}	Address Hold Time	Min	45	ns
t_{DVEH}	t_{DS}	Data Setup Time	Min	40	ns
t_{EHDX}	t_{DH}	Data Hold Time	Min	0	ns
t_{GHEL}	t_{GHEL}	Read Recovery Time before Write (OE# High to CE# Low)	Min	0	ns
t_{WLEL}	t_{WS}	WE# SetupTime	Min	0	ns
t_{EHWH}	t_{WH}	WE# Hold Time	Min	0	ns
t_{ELEH}	t_{CP}	Write Pulse Width	Min	45	ns
t_{EHEL}	t_{CPH}	Write Pulse Width High	Min	20	ns
t_{WHWH1}	t_{WHWH1}	Write Buffer Program Operation (Note 2, 3)	Typ	160	μ s
		Programming Operation (Byte AND word mode)	Typ	8	μ s
			Max	200	μ s
t_{WHWH2}	t_{WHWH2}	Sector Erase Operation	Typ	0.1	s
			Max	2	s

Notes: 1. Not 100% tested.

2. See table.22 Erase and Programming Performance for more information.

3. For 1~32 words bytes programmed.

AC CHARACTERISTICS

Figure 14. AC Waveforms for Chip/Sector Erase Operations Timings

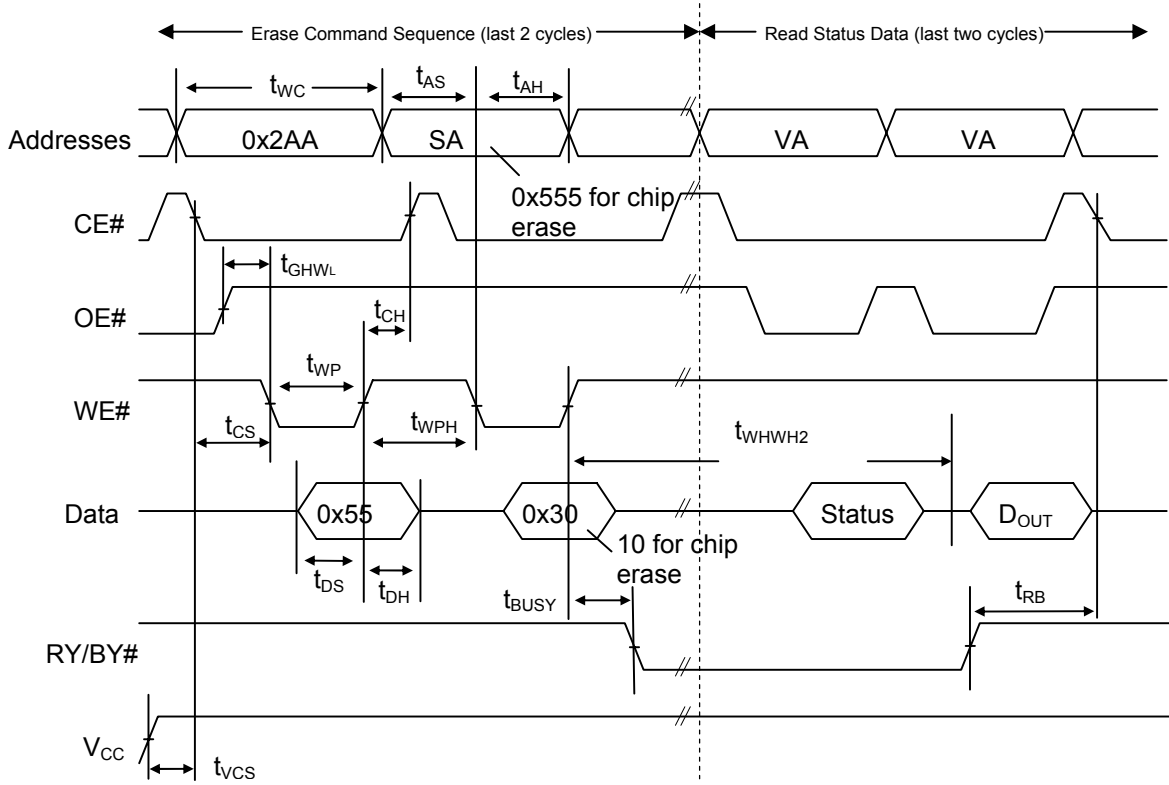

Notes:

1. SA=Sector Address (for sector erase), VA=Valid Address for reading status, D_{out}=true data at read address.
2. V_{cc} shown only to illustrate t_{vcs} measurement references. It cannot occur as shown during a valid command sequence.

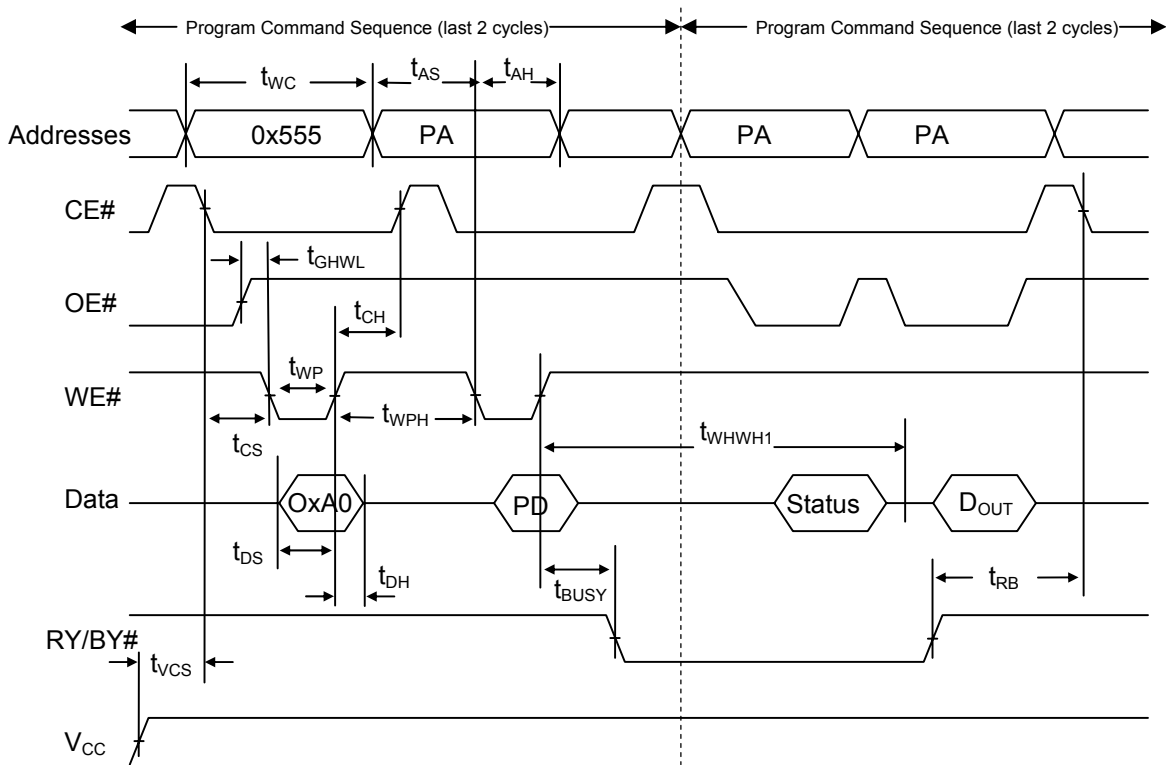
Figure 15. Program Operation Timings

Notes:

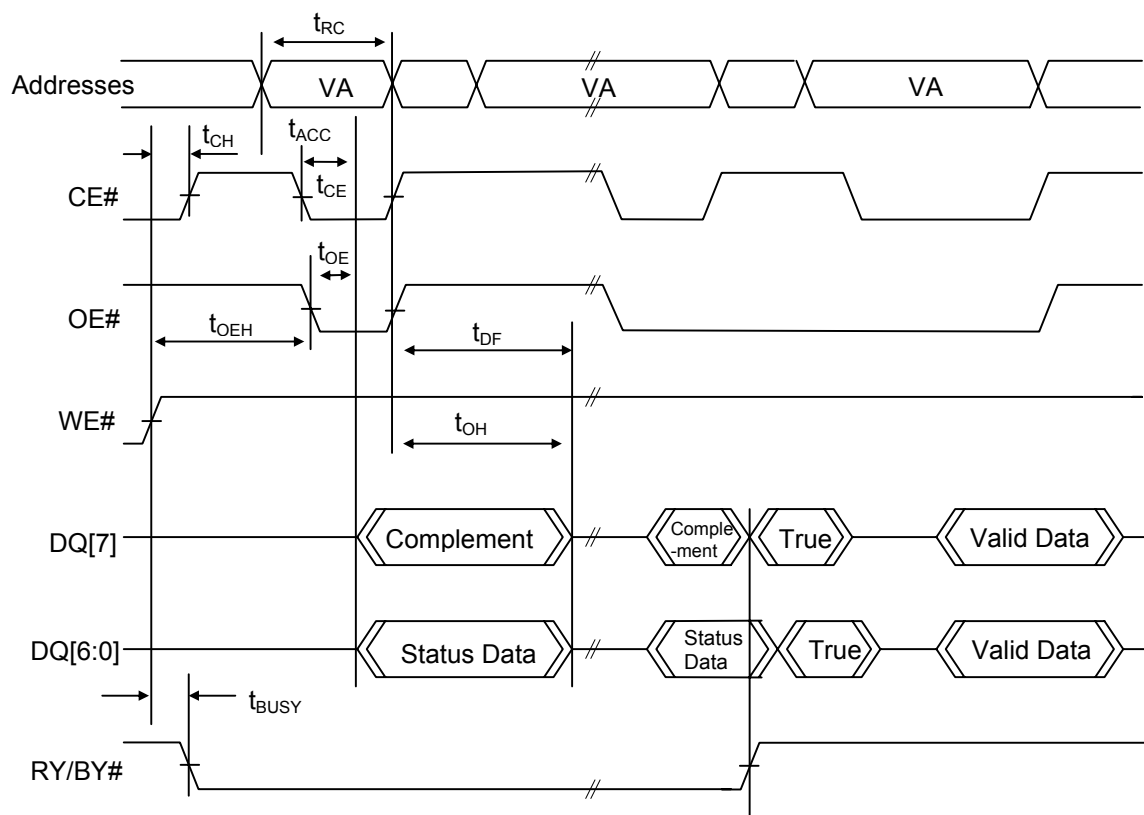
1. PA=Program Address, PD=Program Data, D_{OUT} is the true data at the program address.
2. V_{CC} shown in order to illustrate t_{VCS} measurement references. It cannot occur as shown during a valid command sequence.

Figure 16. AC Waveforms for /DATA Polling During Embedded Algorithm Operations

Notes:

1. VA=Valid Address for reading Data# Polling status data
2. This diagram shows the first status cycle after the command sequence, the last status read cycle and the array data read cycle.

Figure 17. AC Waveforms for Toggle Bit During Embedded Algorithm Operations

Figure 18. Alternate CE# Controlled Write Operation Timings

Notes:

PA = address of the memory location to be programmed.

PD = data to be programmed at byte address.

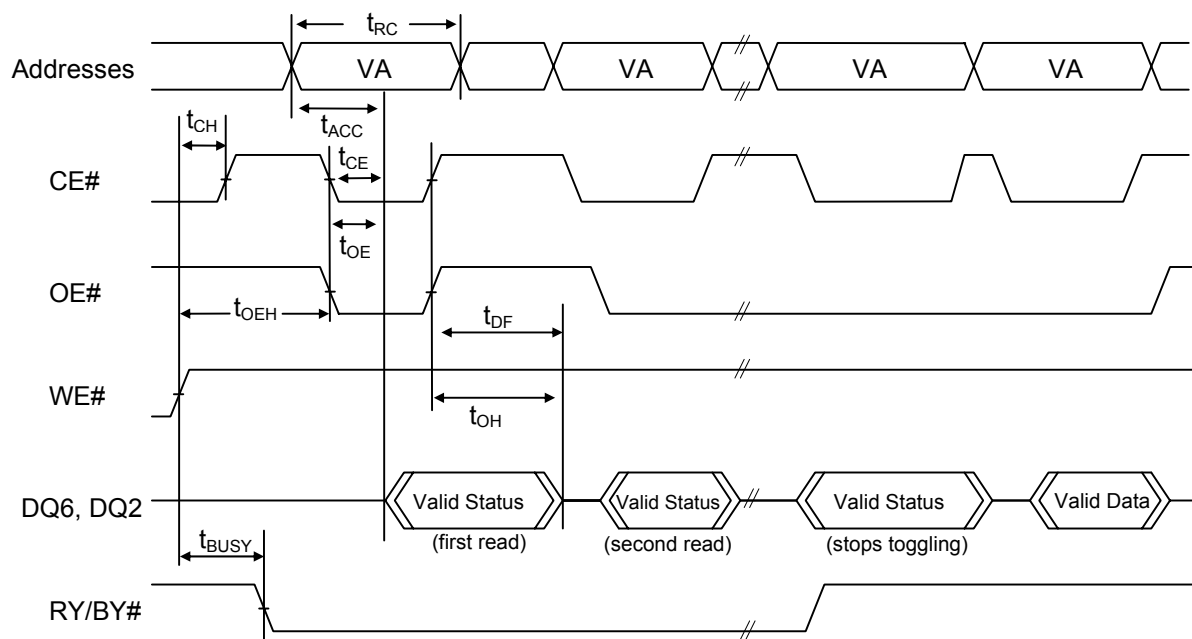
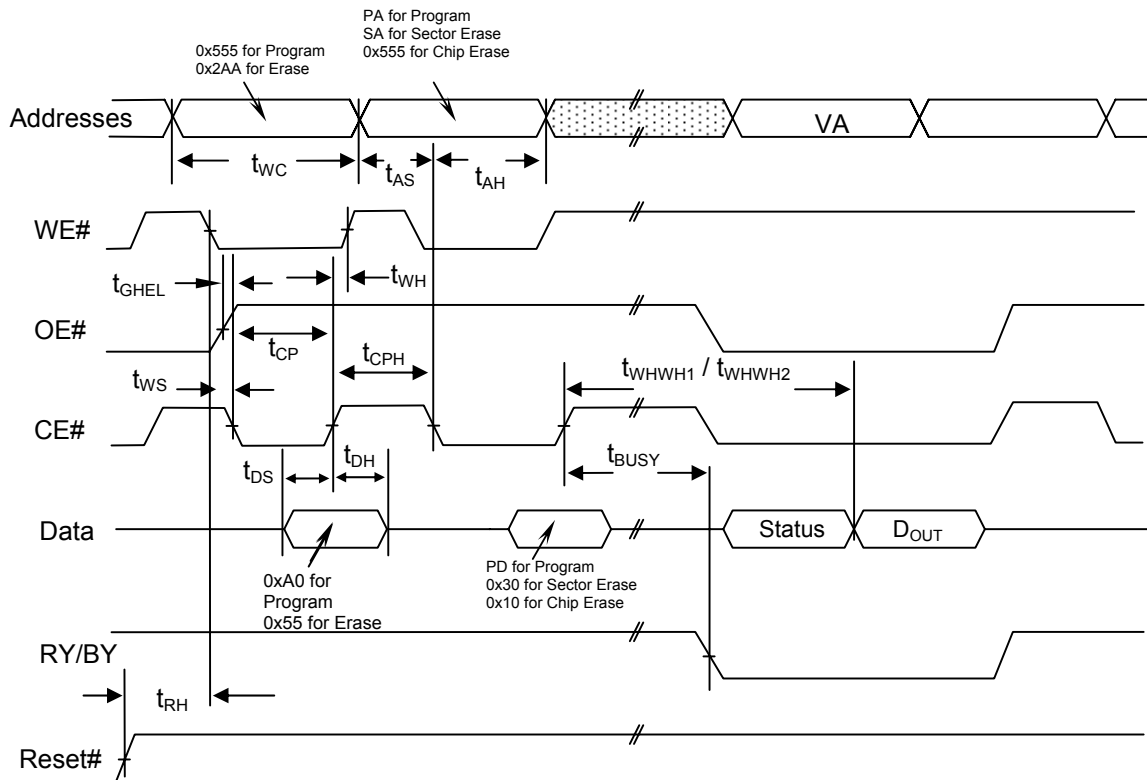
VA = Valid Address for reading program or erase status

D_{out} = array data read at VA

Shown above are the last two cycles of the program or erase command sequence and the last status read cycle
 Reset# shown to illustrate t_{RH} measurement references. It cannot occur as shown during a valid command sequence.

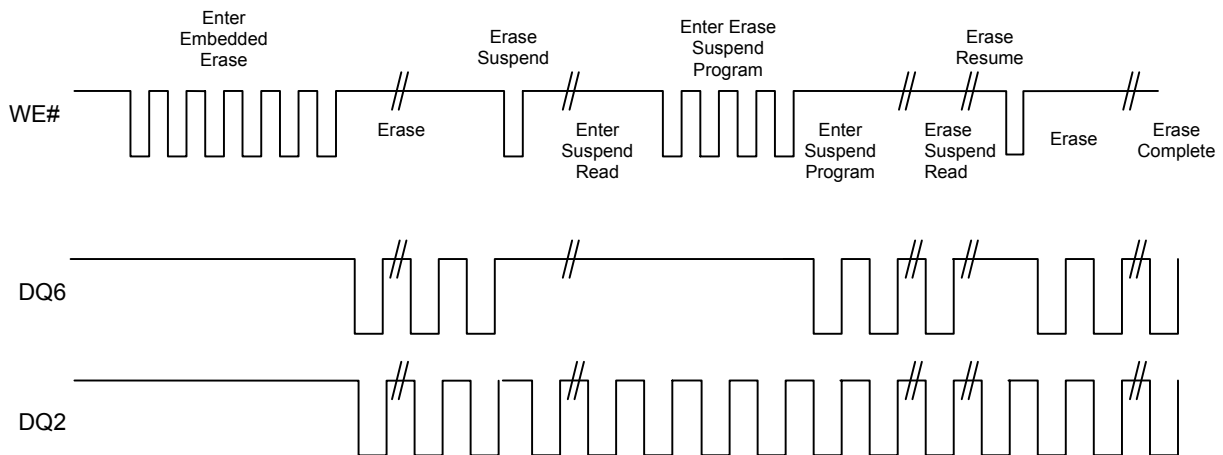
Figure 19. DQ2 vs. DQ6

**TABLE 22. ERASE AND PROGRAMMING PERFORMANCE**

Parameter	Limits			Comments
	Typ	Max	Unit	
Sector Erase Time	0.1	2	sec	Excludes 00h programming prior to erasure
Chip Erase Time	60	240	sec	
Byte Programming Time	8	200	μs	Excludes system level overhead
Word Programming Time	8	200	μs	
Chip Programming Time	Byte	268.8	sec	
	Word	134.4		
Total Write Buffer time	160		μs	
ACC Total Write Buffer time	60			
Erase/Program Endurance	100K		cycles	Minimum 100K cycles

Notes:

1. Typical program and erase times assume the following conditions: room temperature, 3V and checkboard pattern programmed.
2. Maximum program and erase times assume the following conditions: worst case Vcc, 90°C and 100,000 cycles.

Table 23. 56-PIN TSOP PIN CAPACITANCE @ 25°C, 1.0MHz

Parameter Symbol	Parameter Description	Test Setup	Typ	Max	Unit
C _{IN}	Input Capacitance	V _{IN} = 0	6	7.5	pF
C _{OUT}	Output Capacitance	V _{OUT} = 0	8.5	12	pF
C _{IN2}	Control Pin Capacitance	V _{IN} = 0	7.5	9	pF

Note: Test conditions are Temperature = 25°C and f = 1.0 MHz.

Table 24. DATA RETENTION

Parameter Description	Test Conditions	Min	Unit
Data Retention Time	150°C	10	Years
	125°C	20	Years

**ABSOLUTE MAXIMUM RATINGS**

Parameter		Value	Unit
Storage Temperature		-65 to +150	°C
Plastic Packages		-65 to +125	°C
Ambient Temperature With Power Applied		-55 to +125	°C
Output Short Circuit Current ¹		200	mA
Voltage with Respect to Ground	OE#, RESET# and WP#/ACC ²	-0.5 to + 9.5	V
	All other pins ³	-0.5 to V _{cc} +0.5	V
	V _{cc}	-0.5 to + 4.0	V

Notes:

1. No more than one output shorted at a time. Duration of the short circuit should not be greater than one second.
2. Minimum DC input voltage on OE#, RESET# and WP#/ACC pins is -0.5V. During voltage transitions, OE#, RESET# and WP#/ACC pins may undershoot V_{ss} to -1.0V for periods of up to 50ns and to -2.0V for periods of up to 20ns. See figure below. Maximum DC input voltage on OE#, and RESET# is 8.5V which may overshoot to 9.5V for periods up to 20ns.
3. Minimum DC voltage on input or I/O pins is -0.5 V. During voltage transitions, inputs may undershoot V_{ss} to -1.0V for periods of up to 50ns and to -2.0 V for periods of up to 20ns. See figure below. Maximum DC voltage on output and I/O pins is V_{cc} + 0.5 V. During voltage transitions, outputs may overshoot to V_{cc} + 1.5 V for periods up to 20ns. See figure below.
4. Stresses above the values so mentioned above may cause permanent damage to the device. These values are for a stress rating only and do not imply that the device should be operated at conditions up to or above these values. Exposure of the device to the maximum rating values for extended periods of time may adversely affect the device reliability.

RECOMMENDED OPERATING RANGES¹

Parameter	Value	Unit
Ambient Operating Temperature Industrial Devices	-40 to 85	°C
Operating Supply Voltage V _{cc}	Full Voltage Range: 2.7 to 3.6V	V

1. Recommended Operating Ranges define those limits between which the functionality of the device is guaranteed.

Maximum Negative Overshoot
WaveformMaximum Positive Overshoot
Waveform

FIGURE 20. 56L TSOP 14mm x 20mm package outline

SYMBOL	DIMENSION IN MM		
	MIN.	NOR	MAX
A	---	---	1.20
A1	0.05	---	0.15
A2	0.95	1.00	1.05
D	---	20.00	---
D1	---	18.40	---
E	---	14.00	---
e	---	0.50	---
b	0.17	0.22	0.27
L	0.5	0.60	0.70
R	0.08	0.15	0.20
θ	0°	3°	5°

Note : 1. Coplanarity: 0.1 mm

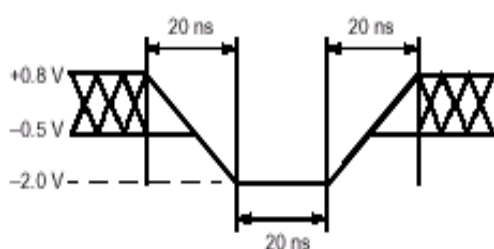
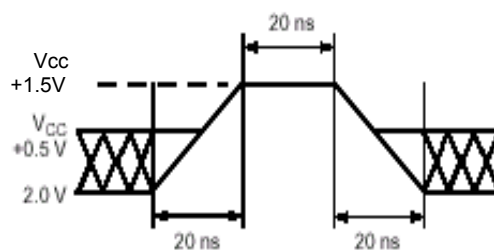
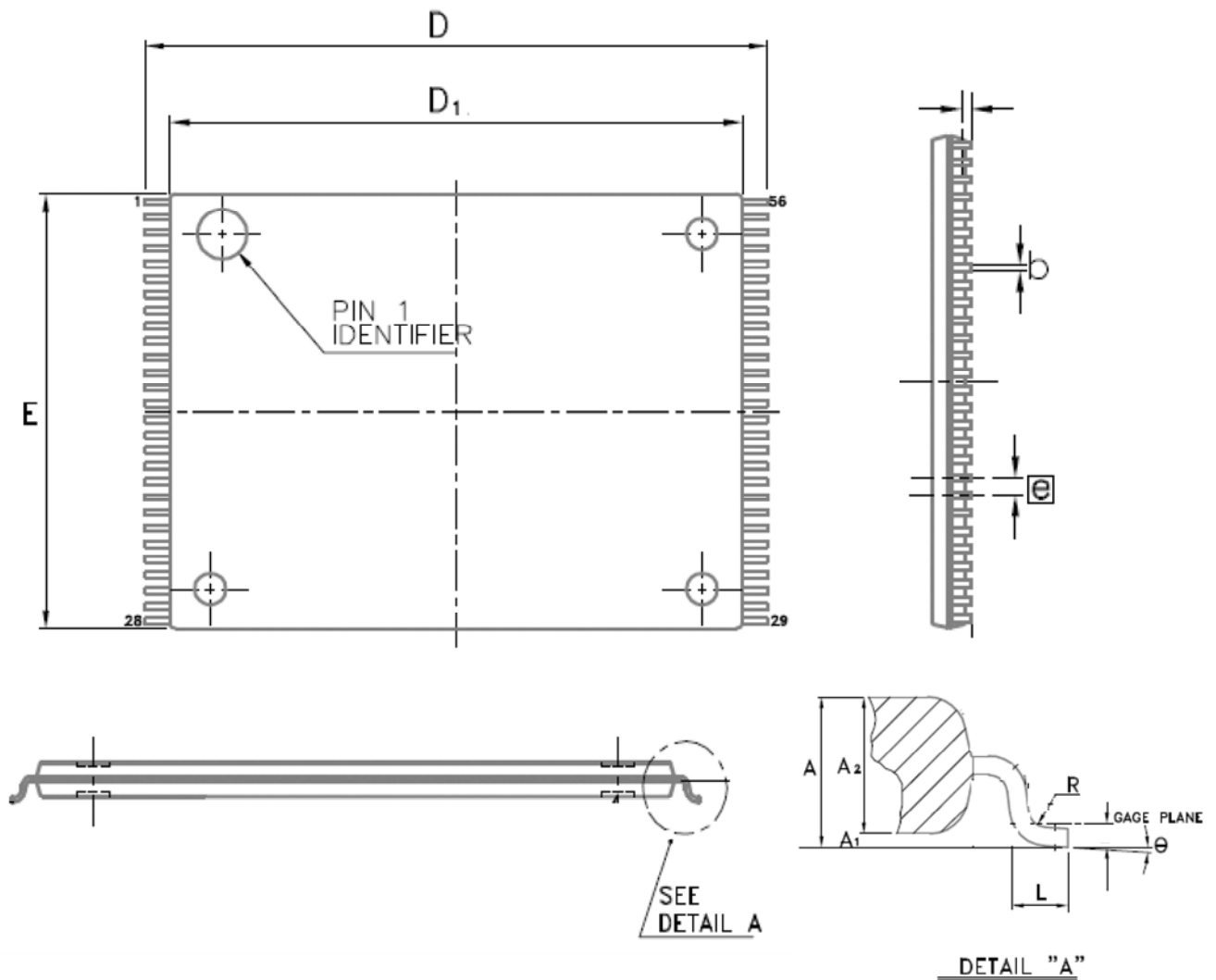

FIGURE 21. 64-ball Ball Grid Array (FBGA), 11 X13 mm, Pitch 1mm package outline

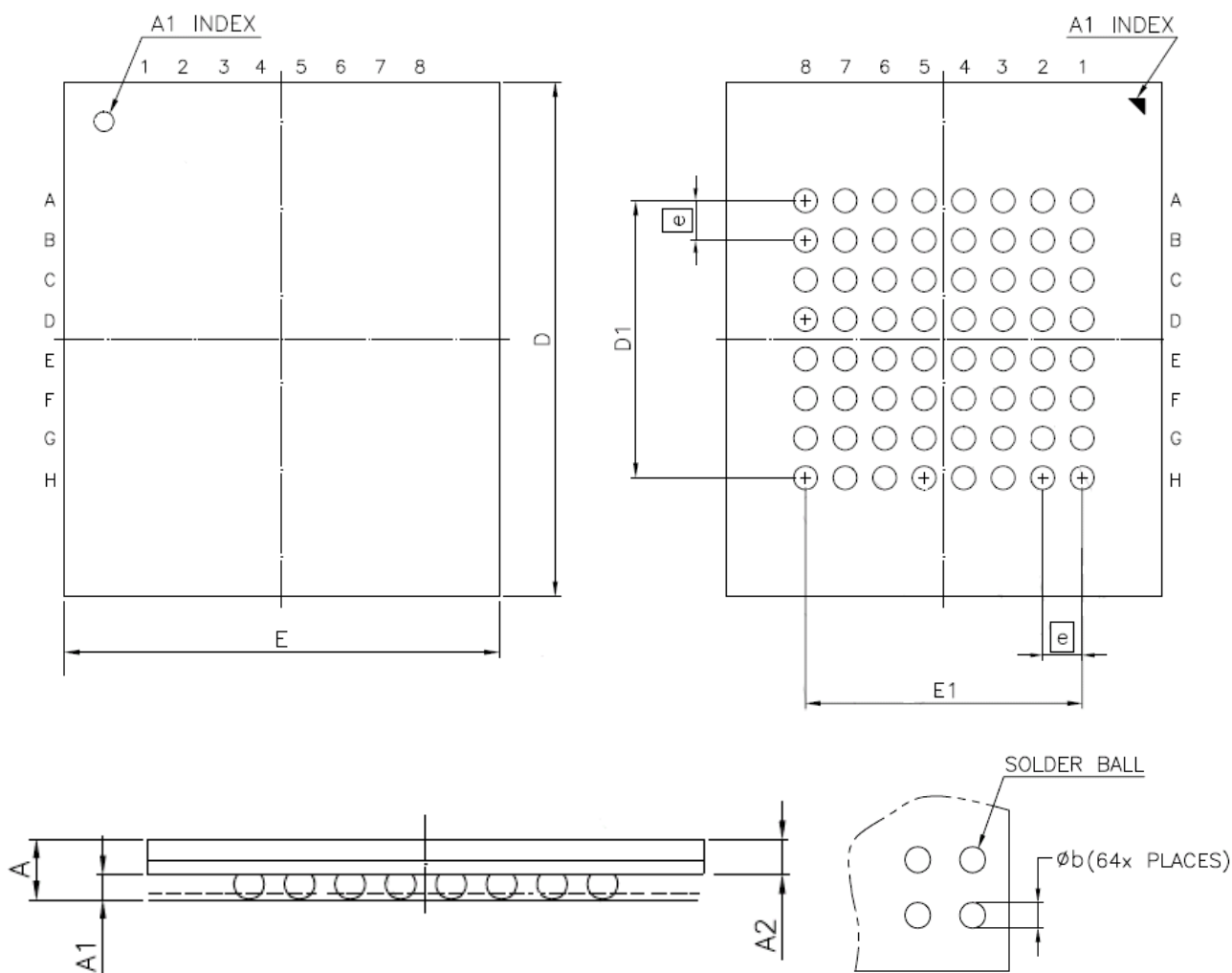

SYMBOL	DIMENSION IN MM		
	MIN.	NOR	MAX
A	---	---	1.40
A1	0.40	0.50	0.60
A2	0.60	0.66	0.76
D	12.90	13.00	13.10
E	10.90	11.00	11.10
D1	---	7.00	---
E1	---	7.00	---
e	---	1.00	---
b	0.50	0.60	0.70



Purpose

Eon Silicon Solution Inc. (hereinafter called “Eon”) is going to provide its products’ top marking on ICs with < cFeon > from January 1st, 2009, and without any change of the part number and the compositions of the ICs. Eon is still keeping the promise of quality for all the products with the same as that of Eon delivered before. Please be advised with the change and appreciate your kindly cooperation and fully support Eon’s product family.

Eon products’ Top Marking

cFeon

cFeon Top Marking Example:

cFeon

Part Number: XXXX-XXX

Lot Number: XXXXX

Date Code: XXXXX

For More Information

Please contact your local sales office for additional information about Eon memory solutions.



ORDERING INFORMATION

EN29GL256 H - 90 Z I P

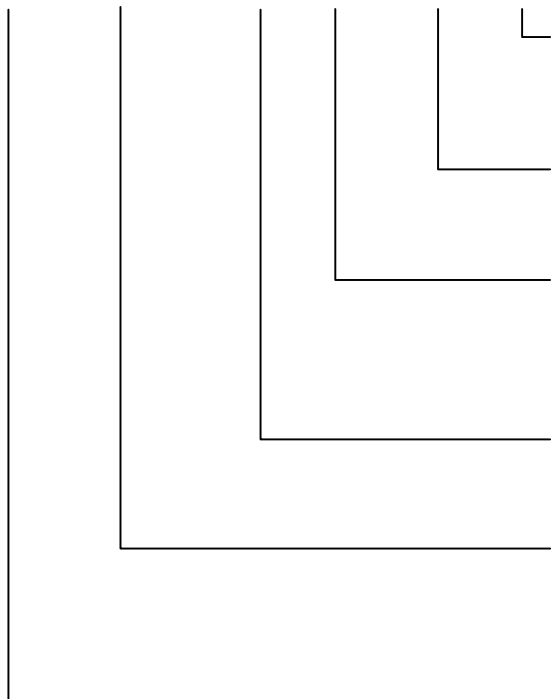

PACKAGING CONTENT

P = RoHS compliant

TEMPERATURE RANGE

I = Industrial (-40°C to +85°C)

PACKAGE

Z = 56-pin TSOP
BA = 64-Ball Ball Grid Array (BGA) 1.0mm pitch,
11mm x 13mm package

SPEED

90 = 90ns

SECTOR for WRITE PROTECT (WP#/ACC=L)

H = highest address sector protected
L = lowest address sector protected

BASE PART NUMBER

EN = Eon Silicon Solution Inc.
29GL = FLASH, 3V Page Mode Flash Memory
256 = 256 Megabit (32M x 8 / 16M x 16)



Revisions List

Revision No	Description	Date
A	Preliminary	2009/02/18
B	<ol style="list-style-type: none">1. Add internal pull-up description for WP# pin in Table1 on Page 42. Add WP#/ACC, VIO pin in Figure3 on Page 43. Modify tOE from 30ns to 25ns in Table 17 on page 40 and Page 54. Add Secured Silicon Sector Entry/Exit command in Table135. Modify typo from Sector Erase Suspend to Erase/Program Suspend, from Sector Erase Resume to Erase/Program resume in Table136. Modify package code for 56-pin TSOP from T to Z in ordering information on Page 577. Del table 22 and Figure 20 Temporary Sector Unprotect Timing table and Diagram and Figure 21.Sector Protect/Unprotect Timing Diagram8. Modify Erase/Program performance in Table 20, 21 and 22. Chip erase time from 64→60sec typ and 560→240sec max. Add ACC and total write buffer time spec9. Del t_{CEH} on table 1710. Modify DC Characteristics in table 15 VHH from 10.5~11.5V to 8.5~9.5V ICC1 5MHz 9→15mA typ, 10MHz 16→25mA typ ICC4, ICC5 and ICC6 1→1.5uA typ, 5→10uA max Add IIO2 and IACCspec11. Del apply VID on address pin A9 to access autoselect codes function. (Remove TABLE 5 and modify description Autoselect section for using High voltage to get Autoselect Codes)12. Modify A9 spec from 9.5V to Vcc+0.5V in ABSOLUTE MAXIMUM RATINGS13. Modify CFI 4Ah, 4Fh description and data of 4Fh in table 1214. Modify CFI data for address 27h and 2Dh.15. Modify typo Sector Architecture 128 to 256 sectors on page116. Modify typo Byte mode to Word mode on page7	2009/05/12
C	<ol style="list-style-type: none">1. Modify naming for DQ0 OTP Lock Bit to Secured Silicon Sector Protection Bit on Page 282. Modify Table.8 Secured Silicon Sector Address Range 000000h-000007h from Determined by customer to Reserve for Factory3. Add note "The address 0h~7h in Secured Silicon Sector is reserved for Factory" on Page 344. Update FIGURE 21. 64 ball Fortified Ball Grid Array (FBGA), 11 X13 mm, Pitch 1mm package outline on page 555. Modify from Sector 0 to all sectors in note 1 of Table 6 and note 2, 3 and note 9 of PPB section on page 286. Add "User only can use DQ6 and RY/BY# pin to detect programming status" in note 10 on page29	2009/7/14
D	Change the package code of 64-ball BGA on page 56.	2009/07/22
E	<ol style="list-style-type: none">1. Correct typo in Table 20, "t_{BUSY}" from Min. to Max on page 45.2. Add a note "when sector SA0 is suspended, if system enters Secured Sector mode,..." on page 32.	2010/01/26
F	<ol style="list-style-type: none">1. Add Write Buffer byte mode command and note that maximum value is 31 for word and byte mode in page 37.2. Change the speed option from 70ns to 90ns, and modify related parameter for 90ns speed.	2010/03/31